



第4章：深度学习基础

中国科学技术大学
电子工程与信息科学系

主讲教师：李厚强 (lihq@ustc.edu.cn)
周文罡 (zhwg@ustc.edu.cn)
李 礼 (lil1@ustc.edu.cn)
胡 洋 (eeyhu@ustc.edu.cn)



深度学习基础

- 深度前馈网络
- 卷积神经网络
- 循环神经网络
- Transformer网络



深度学习基础

- 深度前馈网络
 - 基本结构
 - 非线性激活函数
 - 反向传播算法
 - 优化算法
- 卷积神经网络
- 循环神经网络
- Transformer网络

深度前馈网络

□ 深度前馈网络（多层感知机）

- 深度前馈网络由输入层，隐藏层，输出层组成
- 深度前馈网络本质上是在学习函数映射
- 假设输入 $x_i \in \mathbb{R}^{D_{in}}$ ，输出 $y_i \in \mathbb{R}^{D_{out}}$

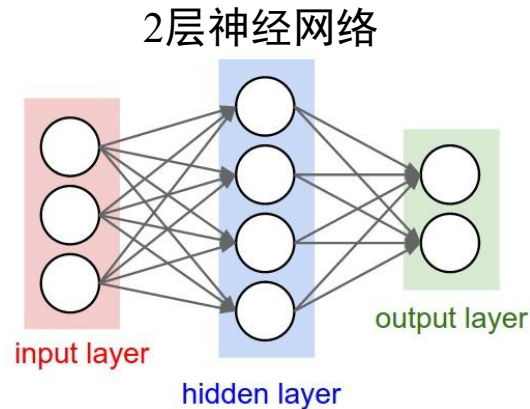

$$g(\mathbf{x}, W_1, W_2) = f(W_2 f(W_1 \mathbf{x}))$$

$$W_1 \in \mathbb{R}^{H \times D_{in}}$$

$$W_2 \in \mathbb{R}^{D_{out} \times H}$$

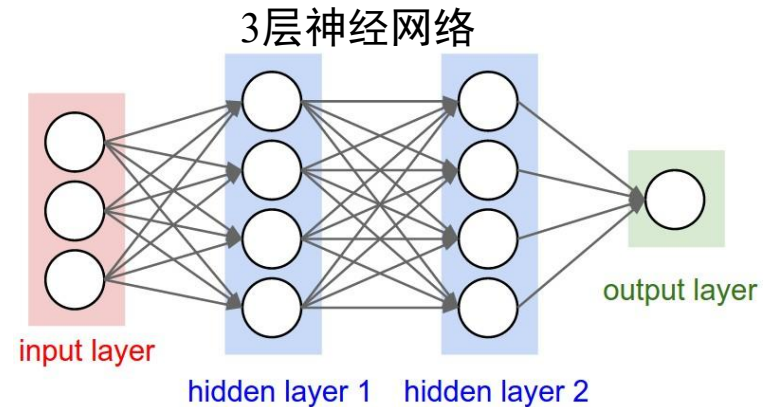

$$g(\mathbf{x}, W_1, W_2, W_3) = f(W_3 f(W_2 f(W_1 \mathbf{x})))$$

$$W_1 \in \mathbb{R}^{H_1 \times D_{in}}$$

$$W_2 \in \mathbb{R}^{H_2 \times H_1}$$

$$W_3 \in \mathbb{R}^{D_{out} \times H_2}$$

前馈网络：示例

□ 神经网络模型

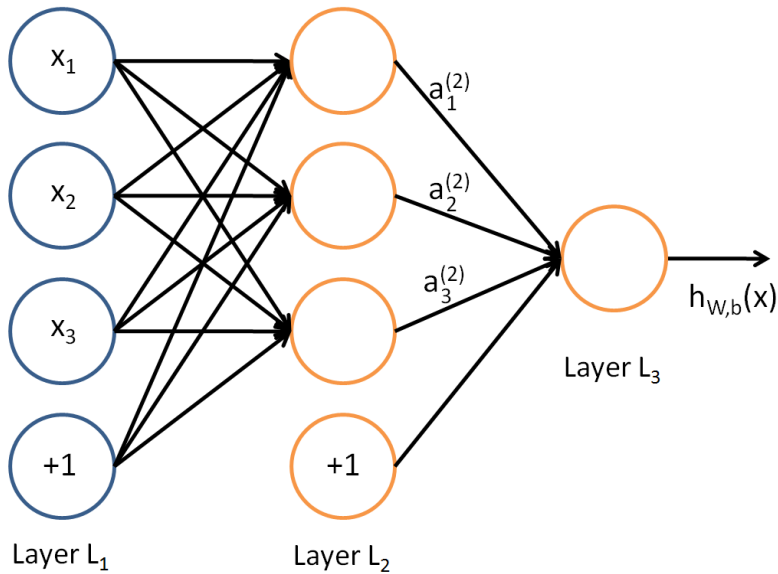

$f(\cdot)$: 激活函数 (activation function)

$a_i^{(l)}$: 第 l 层第 i 单元的输出值

$z_i^{(l)}$: 第 l 层第 i 单元的输入加权和

$$\begin{aligned} a_1^{(2)} &= f(z_1^{(2)}) \\ &= f(W_{11}^{(1)}x_1 + W_{12}^{(1)}x_2 + W_{13}^{(1)}x_3 + b_1^{(1)}) \end{aligned}$$

$$\begin{aligned} a_2^{(2)} &= f(z_2^{(2)}) \\ &= f(W_{21}^{(1)}x_1 + W_{22}^{(1)}x_2 + W_{23}^{(1)}x_3 + b_2^{(1)}) \end{aligned}$$

$$\begin{aligned} a_3^{(2)} &= f(z_3^{(2)}) \\ &= f(W_{31}^{(1)}x_1 + W_{32}^{(1)}x_2 + W_{33}^{(1)}x_3 + b_3^{(1)}) \end{aligned}$$

$$\begin{aligned} h_{W,b}(\mathbf{x}) &= a_1^{(3)} = f(z_1^{(3)}) \\ &= f(W_{11}^{(2)}a_1^{(2)} + W_{12}^{(2)}a_2^{(2)} + W_{13}^{(2)}a_3^{(2)} + b_1^{(2)}) \end{aligned}$$



激活函数

□ 激活函数作用

- 引入非线性，增强网络的表达能力

□ 激活函数的性质

- 非线性，连续可导（允许少数点上不可导）
 - ✓ 可以用数值优化的方法学习网络参数
- 激活函数及其导数尽可能简单
 - ✓ 有利于提高网络计算效率
- 激活函数的导函数的值域在一个合适的区间内
 - ✓ 太大或太小可能影响训练的效率和稳定性



激活函数

□ 常见激活函数

■ S型函数

Sigmoid

$$\sigma(x) = \frac{1}{1 + e^{-x}}$$

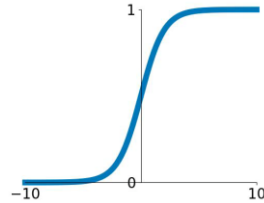

Tanh

$$\tanh(x) = \frac{e^x - e^{-x}}{e^x + e^{-x}}$$

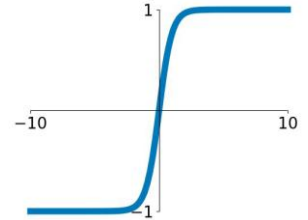

■ 斜坡函数

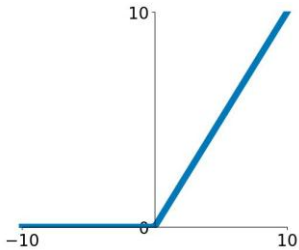

ReLU

$$\max(0, x)$$

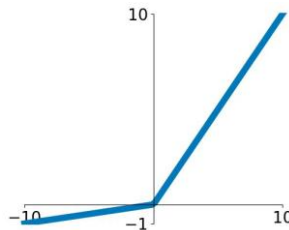

Leaky ReLU

$$\max(\beta x, x)$$

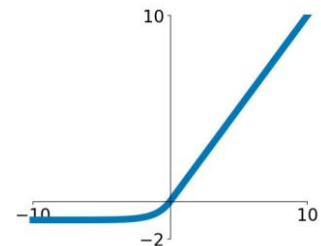

ELU

$$\begin{cases} x, & x \geq 0 \\ \alpha(e^x - 1), & x < 0 \end{cases}$$



万能近似定理

□ 万能近似定理 (universal approximation theorem)

一个前馈神经网络如果具有线性输出层和至少一层具有任何一种“挤压”性质的激活函数（例如sigmoid激活函数）的隐藏层，只要给予网络足够数量的隐藏单元，它可以近似任何一个有限维空间到另一个有限维空间的Borel可测函数。

（定义在 \mathbf{R}^n 的有界闭集上的任意连续函数是Borel可测的，因此可以用神经网络来近似）



训练前馈网络

□ 有监督学习

■ 损失函数

- ✓ 平方损失: $\frac{1}{2} \|h_{\mathbf{W}, b}(\mathbf{x}) - y\|^2$
- ✓ Hinge损失: $\sum_{j \neq y} \max(0, s_j - s_y + 1)$
- ✓ 交叉熵损失: $-\log\left(\frac{e^{s_y}}{\sum_j e^{s_j}}\right)$

■ 给定训练样本集 $\{(\mathbf{x}^{(1)}, y^{(1)}), \dots, (\mathbf{x}^{(m)}, y^{(m)})\}$

$$J(\mathbf{W}, b; \mathbf{x}, y) = \frac{1}{m} \sum_{i=1}^m J(\mathbf{W}, b; \mathbf{x}^{(i)}, y^{(i)}) + \frac{\lambda}{2} \sum_{l=1}^{n_l-1} \sum_{i=1}^{H_l} \sum_{j=1}^{H_{l+1}} (W_{ji}^{(l)})^2$$

公式中第一项为**数据**项，第二项为**正则化**项（也叫**权重衰减**weight decay项），其目的是**减小权重的幅度**，防止过拟合。



反向传播算法

□ 前向计算

- 参数(随机)初始化
- 进行前馈传导计算, 利用前向传导公式, 得到 L_2, L_3, \dots, L_{n_l} 的输出值

$$a_i^{(n_l)} = f(z_i^{(n_l)})$$

- 对于第 n_l 层(输出层)的每个输出单元 i , 由预测值 $h_{w,b}(\mathbf{x})$ 和标签 y 计算网络预测的误差

以平方误差为例 $\frac{1}{2} \|y - f(z_i^{(n_l)})\|^2$



反向传播算法

□ 反向传播

- 由后向前，逐层计算损失函数相对于该层输入的偏导数（误差项）
- 计算 J 对 $z_i^{(n_l)}$ 的偏导数

$$\begin{aligned}\delta_i^{(n_l)} &= \frac{\partial}{\partial z_i^{(n_l)}} J(\mathbf{W}, b; \mathbf{x}, y) \\ &= \frac{\partial}{\partial z_i^{(n_l)}} \frac{1}{2} \|y - f(z_i^{(n_l)})\|^2 && \text{以平方误差为例} \\ &= -(y - a_i^{(n_l)}) \cdot f'(z_i^{(n_l)})\end{aligned}$$

反向传播算法

□ 反向传播

- 由求导的链式法则，第 $n_l - 1$ 层中的第 i 个节点的误差项可由第 n_l 层的误差项计算得到

$$\begin{aligned}
 \delta_i^{(n_l-1)} &= \frac{\partial}{\partial z_i^{(n_l-1)}} J(\mathbf{W}, b; \mathbf{x}, y) = \sum_j \frac{\partial}{\partial z_j^{(n_l)}} J(\mathbf{W}, b; \mathbf{x}, y) \cdot \frac{\partial z_j^{(n_l)}}{\partial z_i^{(n_l-1)}} \\
 &= \sum_j \delta_j^{(n_l)} \cdot \frac{\partial}{\partial z_i^{(n_l-1)}} \left[\sum_k W_{jk}^{(n_l-1)} f(z_k^{(n_l-1)}) \right] \\
 &= \sum_j \delta_j^{(n_l)} \cdot \frac{\partial}{\partial z_i^{(n_l-1)}} \left[W_{ji}^{(n_l-1)} f(z_i^{(n_l-1)}) \right] \\
 &= \sum_j \delta_j^{(n_l)} \cdot W_{ji}^{(n_l-1)} \cdot f'(z_i^{(n_l-1)}) \\
 &= f'(z_i^{(n_l-1)}) \cdot \sum_j (W_{ji}^{(n_l-1)} \cdot \delta_j^{(n_l)})
 \end{aligned}$$

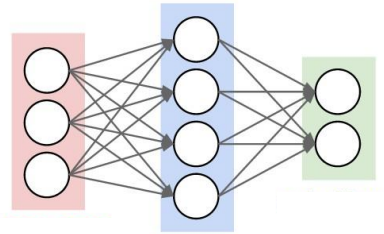

上式可以一般化地表示为: $\delta_i^{(l)} = (\sum_{j=1}^{s_{l+1}} W_{ji}^{(l)} \delta_j^{(l+1)}) f'(z_i^{(l)})$



反向传播算法

□ 反向传播

- 根据误差计算网络参数的梯度

$$\frac{\partial}{\partial W_{ij}^{(l)}} J(\mathbf{W}, b; \mathbf{x}, y) = a_j^{(l)} \delta_i^{(l+1)}$$

$$\frac{\partial}{\partial b_i^{(l)}} J(\mathbf{W}, b; \mathbf{x}, y) = \delta_i^{(l+1)}$$

- 使用梯度下降进行参数更新

□ 重复前向和后向传播过程，直到达到停止条件

反向传播算法

□ 计算图

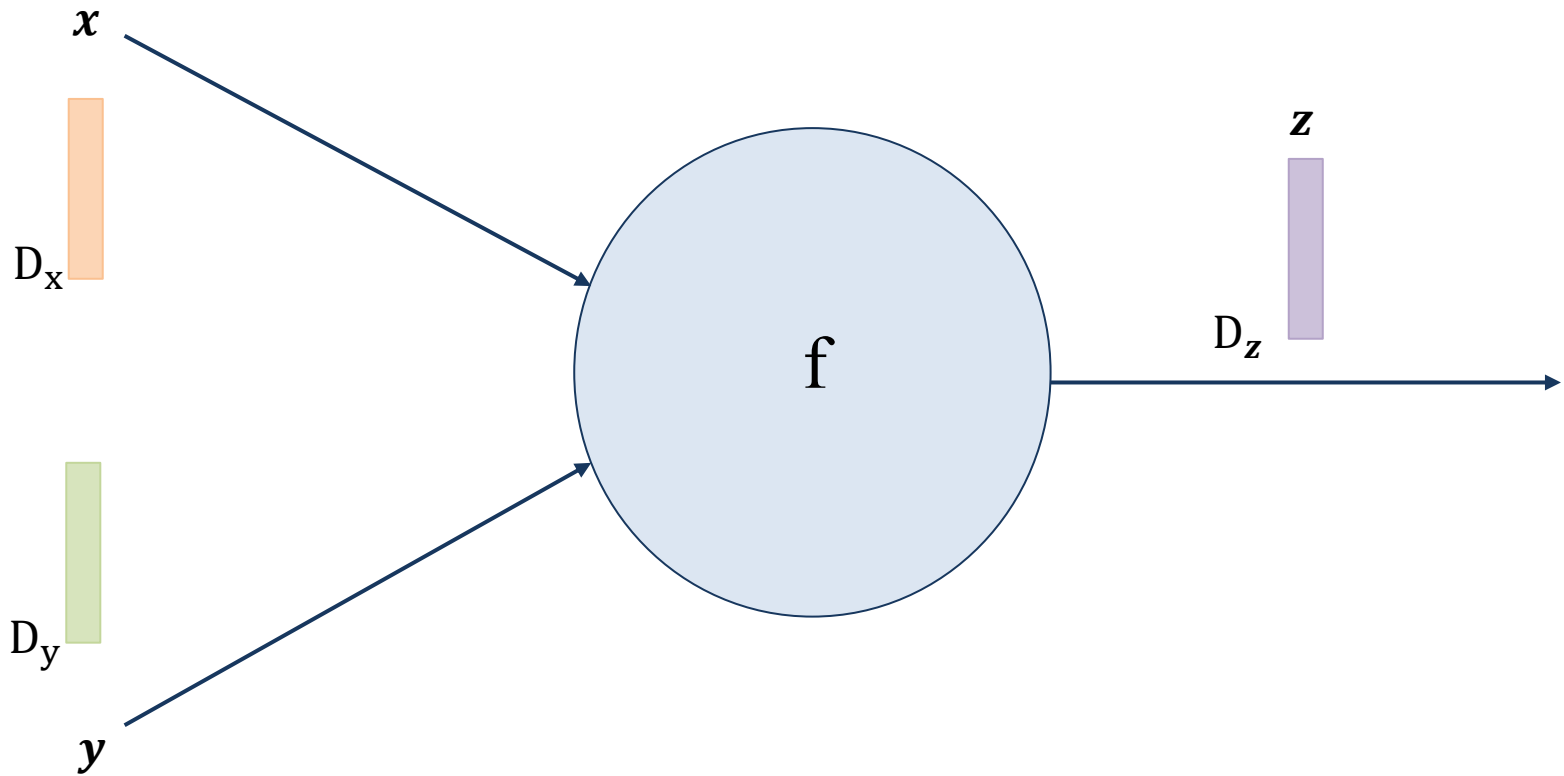

反向传播算法

□ 计算图

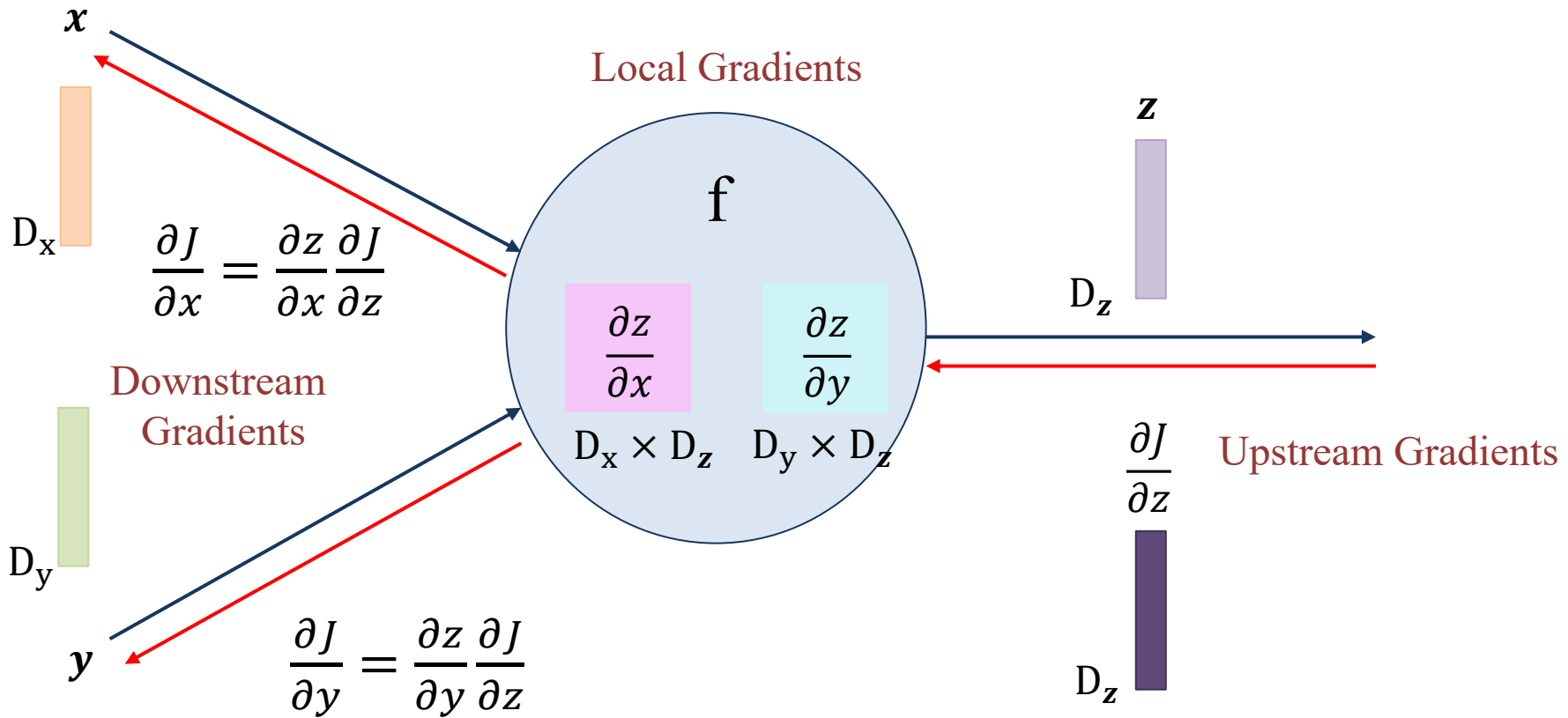

反向传播算法

□ 计算图

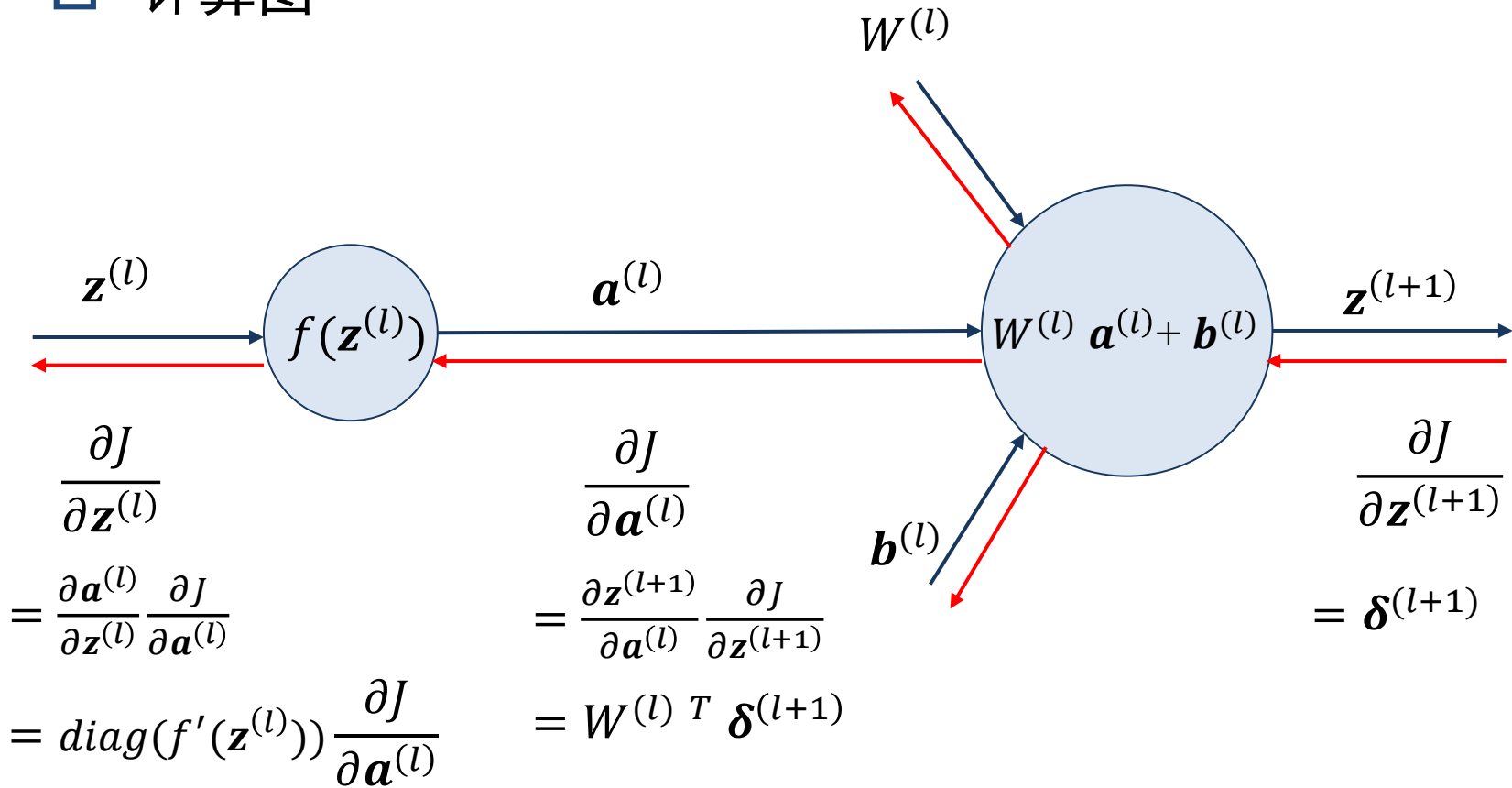



神经网络优化算法

- 梯度下降法

- 梯度下降法的改进
 - Momentum
 - AdaGrad
 - RMSProp
 - Adam



梯度下降法

□ 梯度的概念

■ 梯度的定义

- 梯度是一个矢量
- 梯度对应的方向上的方向导数最大
- 梯度的大小即为最大的方向导数的值

$$\text{grad}f(x_0, x_1, \dots, x_n) = \left(\frac{\partial f}{\partial x_0}, \dots, \frac{\partial f}{\partial x_j}, \dots, \frac{\partial f}{\partial x_n} \right)$$

- 收敛到全局最优解，在非凸问题上可能收敛到局部最优解
梯度下降法：函数沿梯度方向有最大的变化率，优化目标损失函数时，根据负梯度方向进行
- 收敛性：在凸问题上可保证



梯度下降法

□ 梯度下降

$$\theta_{t+1} = \theta_t - \eta \cdot \nabla_{\theta} \mathcal{L}(\theta_t)$$

- η 为学习率

□ 随机梯度下降

$$\theta_{t+1} = \theta_t - \eta \cdot \nabla_{\theta} \mathcal{L}(\theta_t; x^i, y^i)$$

□ 小批量随机梯度下降

$$\theta_{t+1} = \theta_t - \eta \cdot \nabla_{\theta} \mathcal{L}(\theta_t; x^{i:i+n}, y^{i:i+n})$$



梯度下降法的改进

□ Momentum

- 改善SGD方法中的高方差振荡导致的收敛不稳定问题
- 使用最近一段时间内梯度的加权平均值，加强当前更新时在相关方向的梯度下降，削弱在振荡方向的梯度下降

$$v_t = \gamma \cdot v_{t-1} + \eta \cdot \nabla_{\theta} \mathcal{L}(\theta)$$

$$\theta = \theta - v_t$$

式中 γ 为上一步更新向量对当前步骤的影响，通常取0.9

当我们在之前一段时间一直趋向于从某个方向往下走，而当前时刻梯度告诉我们要进行很大的变化时，我们通常会有所迟疑，并根据之前的经验与当前时刻的情况作出调整。



梯度下降法的改进

□ AdaGrad

- 自适应地调整每个参数的学习率

计算梯度: $g = \nabla_{\theta} \mathcal{L}(\theta)$

优势: 不需要手工调整学习率

累计平方梯度: $r = r + g \odot g$

劣势: 从训练开始时积累梯度平方会导致有效学习率过早和过量的减小（学习率过快接近0）

计算更新量: $\Delta\theta = -\frac{\eta}{\epsilon + \sqrt{r}} \odot g$

参数更新: $\theta = \theta + \Delta\theta$

式中 r 为梯度累计变量，训练开始时初始化为0
 ϵ 为一个极小的常数



梯度下降法的改进

□ RMSProp

- 在计算累计平方梯度时加入关于历史信息的衰减系数（平方梯度的指数衰减平均值）

计算梯度：
$$g = \nabla_{\theta} \mathcal{L}(\theta)$$

平方梯度的指数衰减平均值：
$$r = \rho \cdot r + (1 - \rho) \cdot g \odot g$$

计算更新量：
$$\Delta \theta = -\frac{\eta}{\epsilon + \sqrt{r}} \odot g$$

参数更新：
$$\theta = \theta + \Delta \theta$$

Hinton建议历史信息衰减系数 ρ 取0.9，学习率取0.001



梯度下降法的改进

□ Adam (Adaptive Moment Estimation)

- 不仅记录平方梯度的指数衰减平均值，还记录先前梯度的指数衰减平均值，在RMSProp的基础上加入了Momentum的思想

计算梯度：
$$g = \nabla_{\theta} \mathcal{L}(\theta)$$

计算指数衰减平均值：
$$m_t = \beta_1 \cdot m_{t-1} + (1 - \beta_1) \cdot g_t$$

$$v_t = \beta_2 \cdot v_{t-1} + (1 - \beta_2) \cdot g_t \odot g_t$$

一阶矩和二阶矩估计：
$$\hat{m}_t = \frac{m_t}{1 - \beta_1^t} \quad \hat{v}_t = \frac{v_t}{1 - \beta_2^t}$$

参数更新：
$$\theta_{t+1} = \theta_t - \frac{\eta}{\epsilon + \sqrt{\hat{v}_t}} \hat{m}_t$$

通常 β_1 取0.9， β_2 取0.999



深度学习基础

- 深度前馈网络
- 卷积神经网络
 - 卷积层
 - 汇聚层
 - 归一化层
 - 现代经典卷积网络
- 循环神经网络
- Transformer网络

卷积神经网络

□ 全连接层回顾

- 在全连接下，输出层的每一个值和输入的所有值都有关系
- 存在问题：当输入层和输出层维度较高，则参数规模庞大

32x32x3 image -> stretch to 3072 x 1

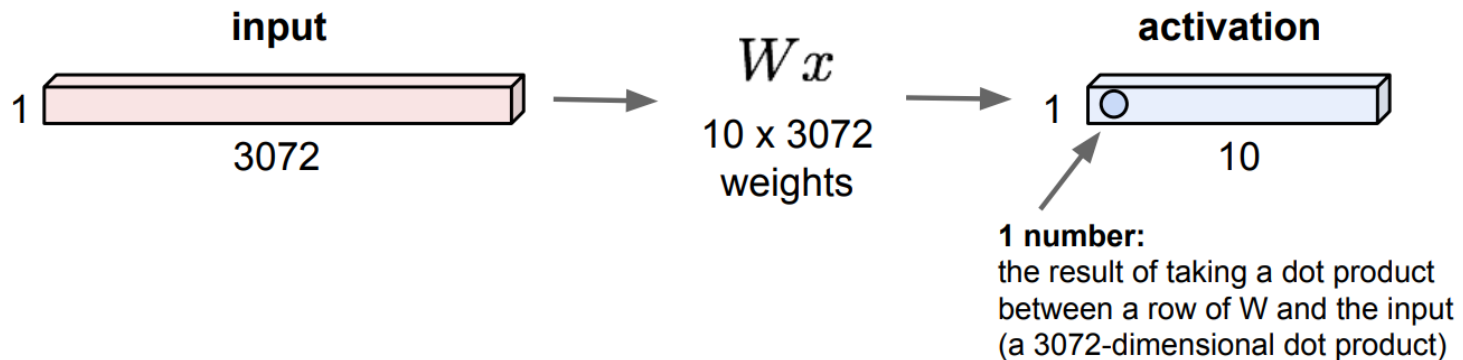

卷积神经网络

- 局部感受野 (local receptive field)
- 权值共享 (weight sharing)

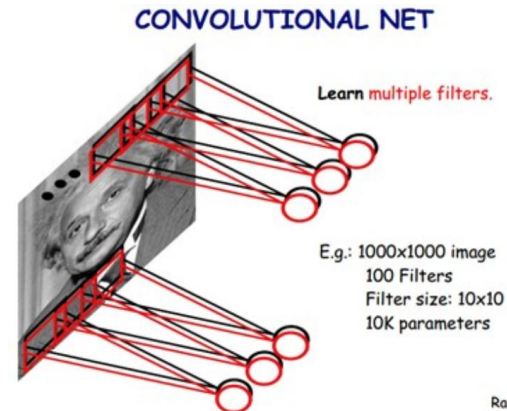
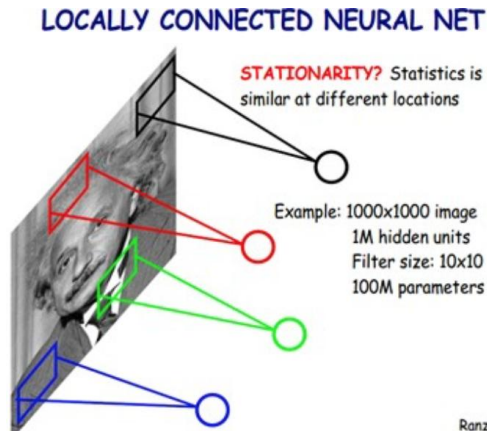
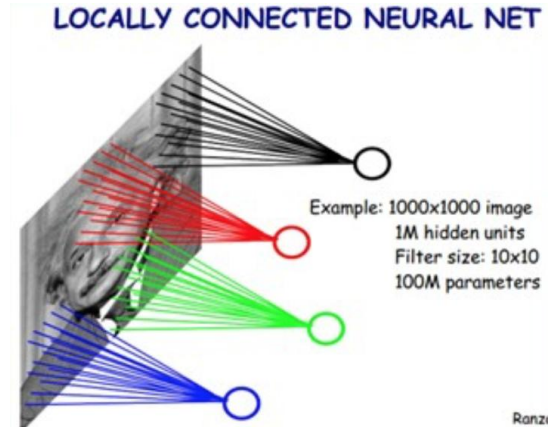
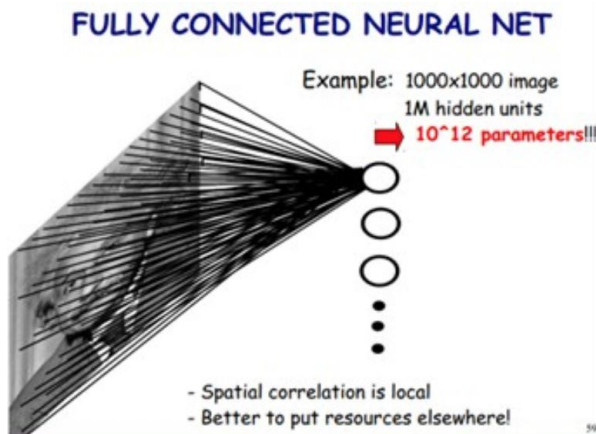

卷积神经网络

□ 卷积层

32x32x3 image

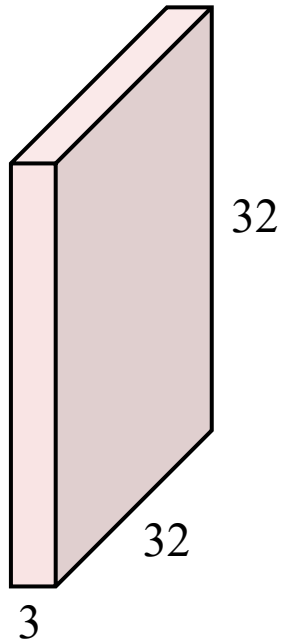

5x5x3 filter



Convolve the filter with the image
i.e. “slide over the image spatially,
computing dot products”

卷积神经网络

□ 卷积层

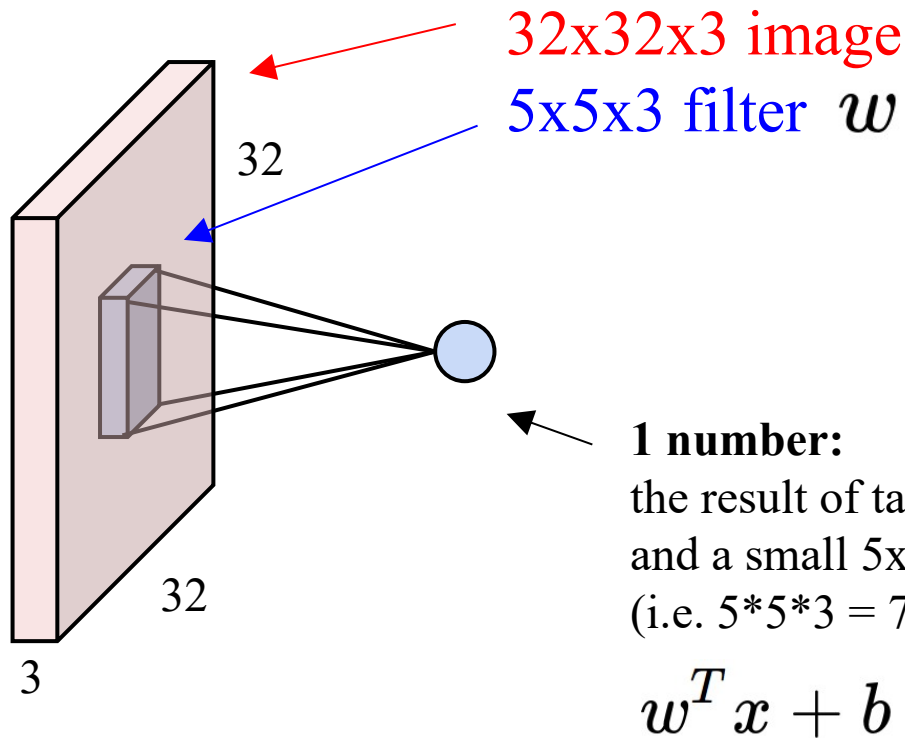

卷积神经网络

□ 卷积层

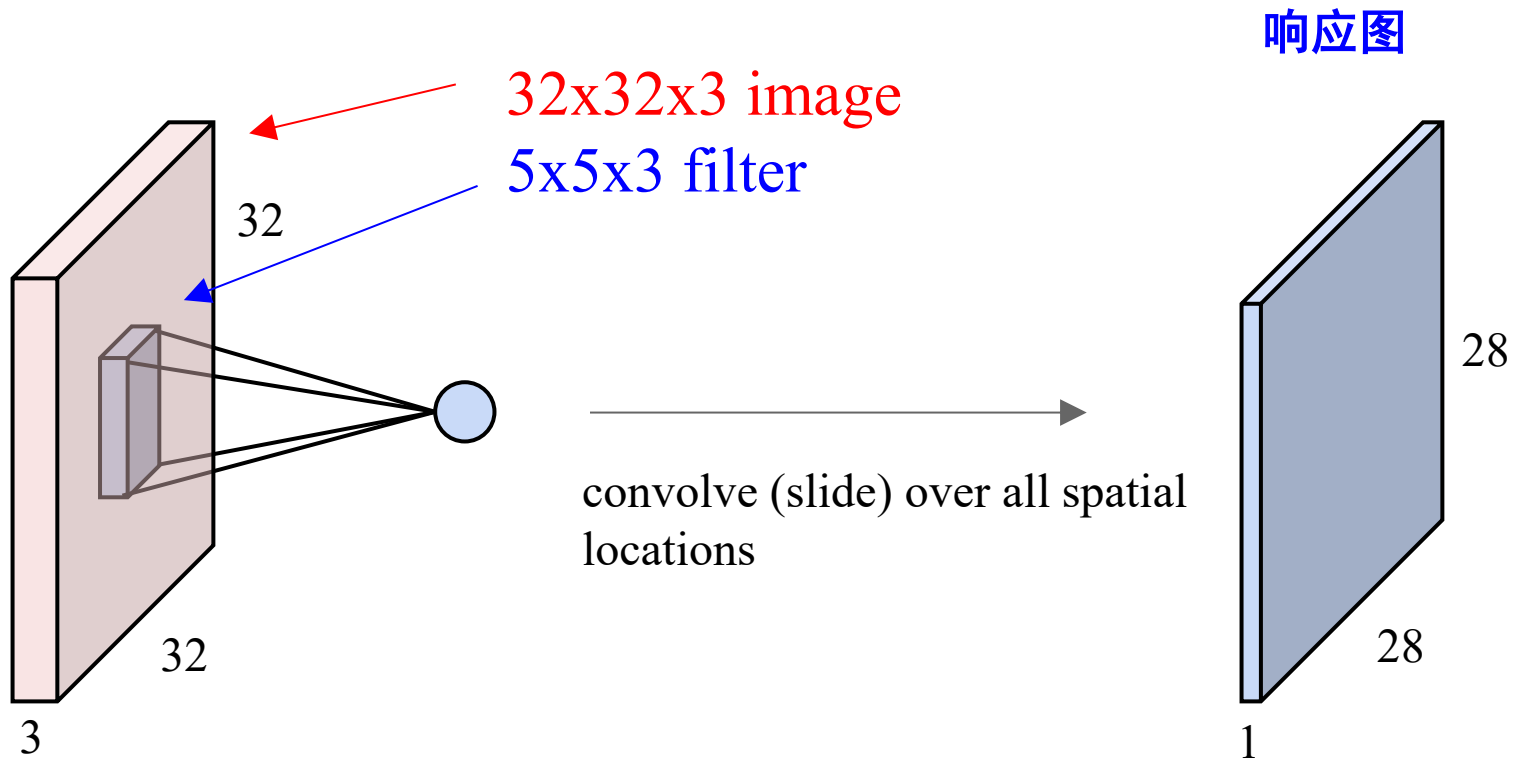

Translation Invariance!

卷积神经网络

□ 卷积层

考虑第二个滤波器（绿色）

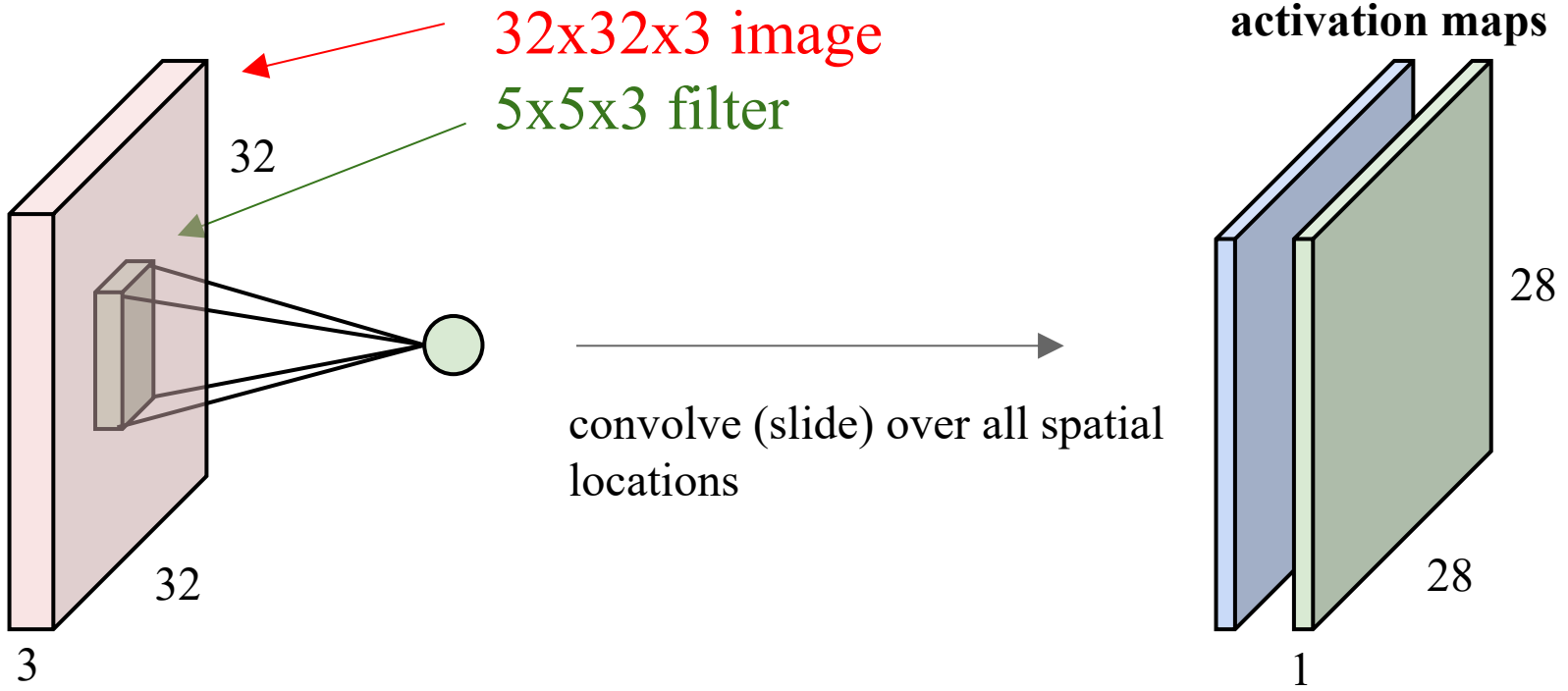

卷积神经网络

□ 卷积层

如果我们有6个5x5的滤波器, 则可以得到6个不同的响应图

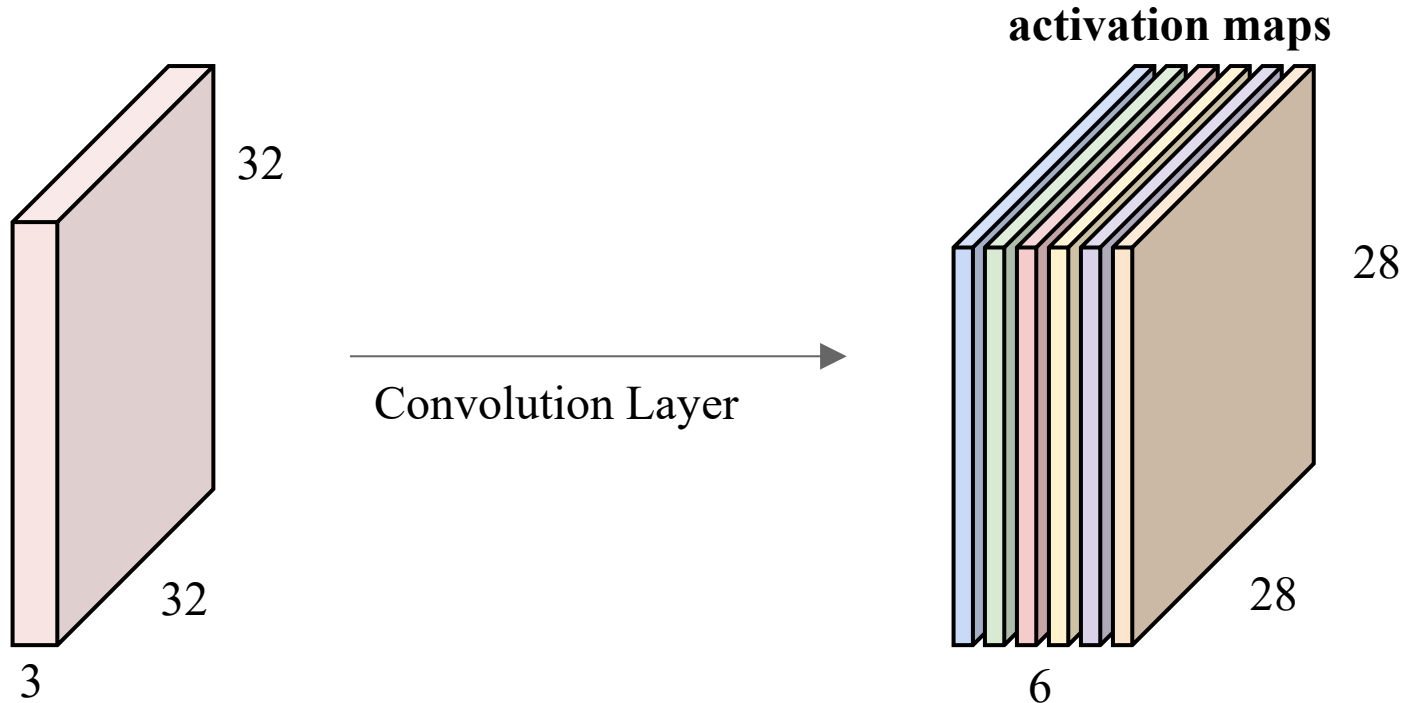

We stack these up to get a “new image” of size 28x28x6!

Number of parameters: F^2CK and K biases

卷积神经网络

□ 卷积操作

7x7 input (spatially)
assume 3x3 filter

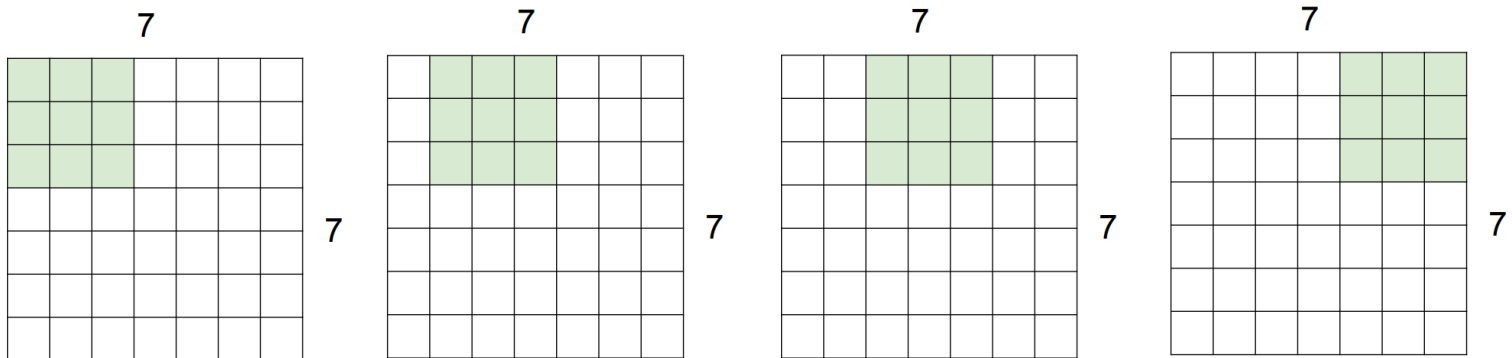

当stride为1，不做padding时，得到 5×5 的feature map

Output size: $(N+2P-F) / \text{stride} + 1$

卷积神经网络

□ 汇聚层（池化层）

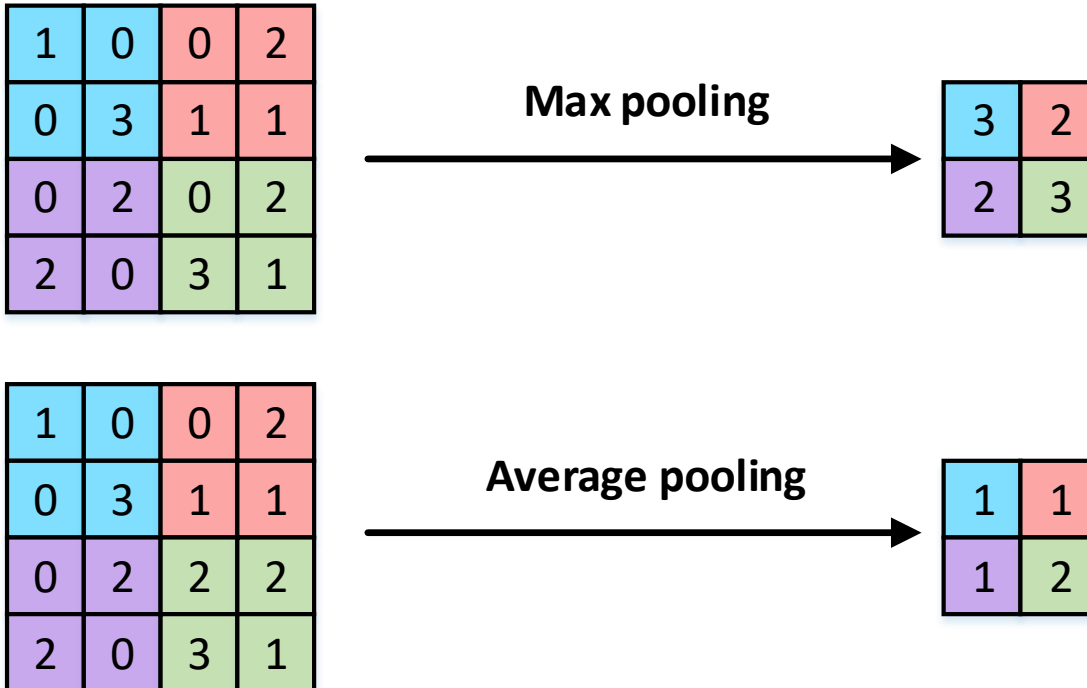

卷积神经网络

□ 实例：LeNet-5

Gradient-based learning applied to document recognition

[LeCun, Bottou, Bengio, Haffner 1998]

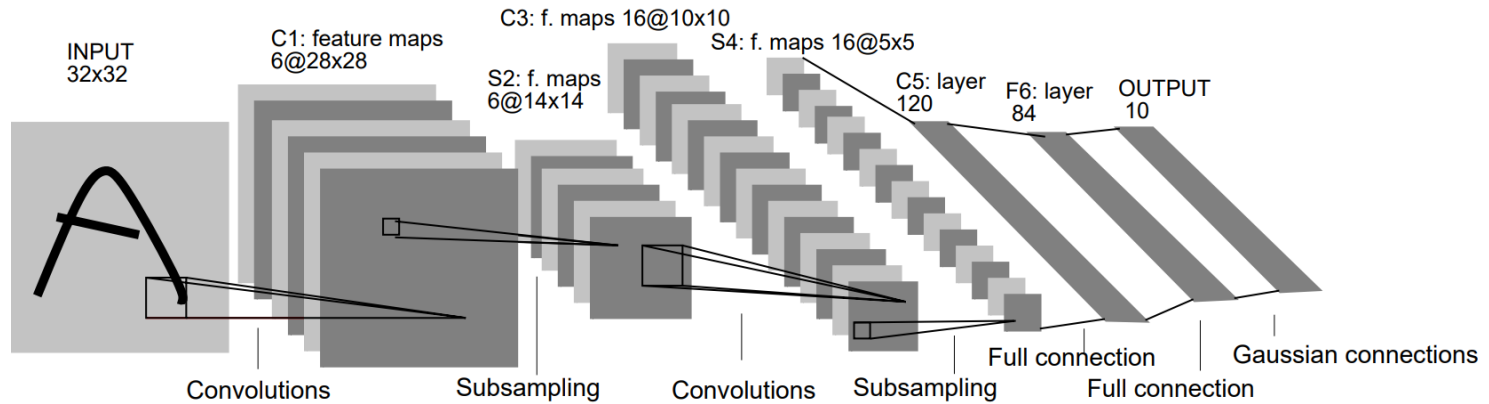

与现在常见的卷积神经网络结构不同，LeNet-5的**下采样层**不是用池化层实现，而是先将 2×2 的窗口中的4个输入相加，乘以一个可训练参数，再加上一个可训练偏置，输出的结果通过sigmoid激活

- Y. LeCun, L. Bottou, Y. Bengio, and P. Haffner, “Gradient-based learning applied to document recognition”. In Proceedings of the IEEE, 86(11):2278–2324, 1998.

批量归一化

□ 问题

中间层输出数值的不稳定性，给深度神经网络的训练带来困难

□ 解决办法

利用小批量上的均值和标准差，调整中间层输出

□ 假设输入 $x \in \mathbb{R}^{N \times D}$

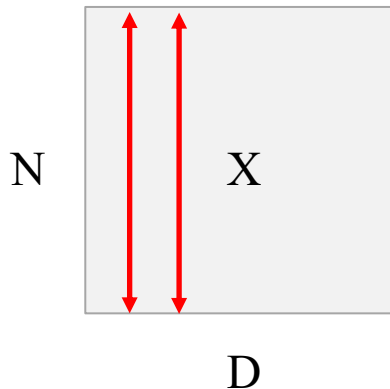

$$\mu_j = \frac{1}{N} \sum_{i=1}^N x_{i,j}$$

$$\sigma_j^2 = \frac{1}{N} \sum_{i=1}^N (x_{i,j} - \mu_j)^2$$

$$\hat{x}_{i,j} = \frac{x_{i,j} - \mu_j}{\sqrt{\sigma_j^2 + \varepsilon}}$$

$$y_{i,j} = \gamma_j \hat{x}_{i,j} + \beta_j$$

γ 、 β 为可学习的参数



批量归一化

□ 全连接层的批量归一化

$$x : N \times D$$

归一化

$$\mu, \sigma : 1 \times D$$

$$\gamma, \beta : 1 \times D$$

$$y = \frac{(x - \mu)}{\sqrt{\sigma^2 + \varepsilon}} \gamma + \beta$$

□ 卷积层的批量归一化

$$x : N \times C \times H \times W$$

归一化

$$\mu, \sigma : 1 \times C \times 1 \times 1$$

$$\gamma, \beta : 1 \times C \times 1 \times 1$$

$$y = \frac{(x - \mu)}{\sqrt{\sigma^2 + \varepsilon}} \gamma + \beta$$



层归一化

□ 全连接层的批量归一化

$$x : N \times D$$

归一化



$$\mu, \sigma : 1 \times D$$

$$\gamma, \beta : 1 \times D$$

$$y = \frac{(x - \mu)}{\sqrt{\sigma^2 + \varepsilon}} \gamma + \beta$$

□ 层归一化

(RNN, Transformers)

$$x : N \times D$$

归一化



$$\mu, \sigma : N \times 1$$

$$\gamma, \beta : 1 \times D$$

$$y = \frac{(x - \mu)}{\sqrt{\sigma^2 + \varepsilon}} \gamma + \beta$$



实例归一化

□ 卷积层的批量归一化

□ 卷积层的实例归一化

$$x : N \times C \times H \times W$$

归一化



$$\mu, \sigma : 1 \times C \times 1 \times 1$$

$$\gamma, \beta : 1 \times C \times 1 \times 1$$

$$y = \frac{(x - \mu)}{\sqrt{\sigma^2 + \varepsilon}} \gamma + \beta$$

$$x : N \times C \times H \times W$$

归一化

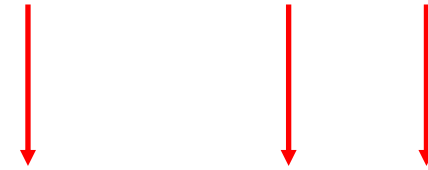

$$\mu, \sigma : N \times C \times 1 \times 1$$

$$\gamma, \beta : 1 \times C \times 1 \times 1$$

$$y = \frac{(x - \mu)}{\sqrt{\sigma^2 + \varepsilon}} \gamma + \beta$$



现代经典卷积神经网络

- 经典图像分类网络
 - AlexNet
 - VGGNet
 - GoogLeNet
 - ResNet
 - MobileNet

图像分类任务的巨大进展

- 随着深度卷积神经网络的发展，图像分类的准确率得到了极大的提升
 - 核心因素：数据、算力、算法
 - 对人工设计特征造成的巨大冲击

ImageNet Large Scale Visual Recognition Challenge (ILSVRC) winners

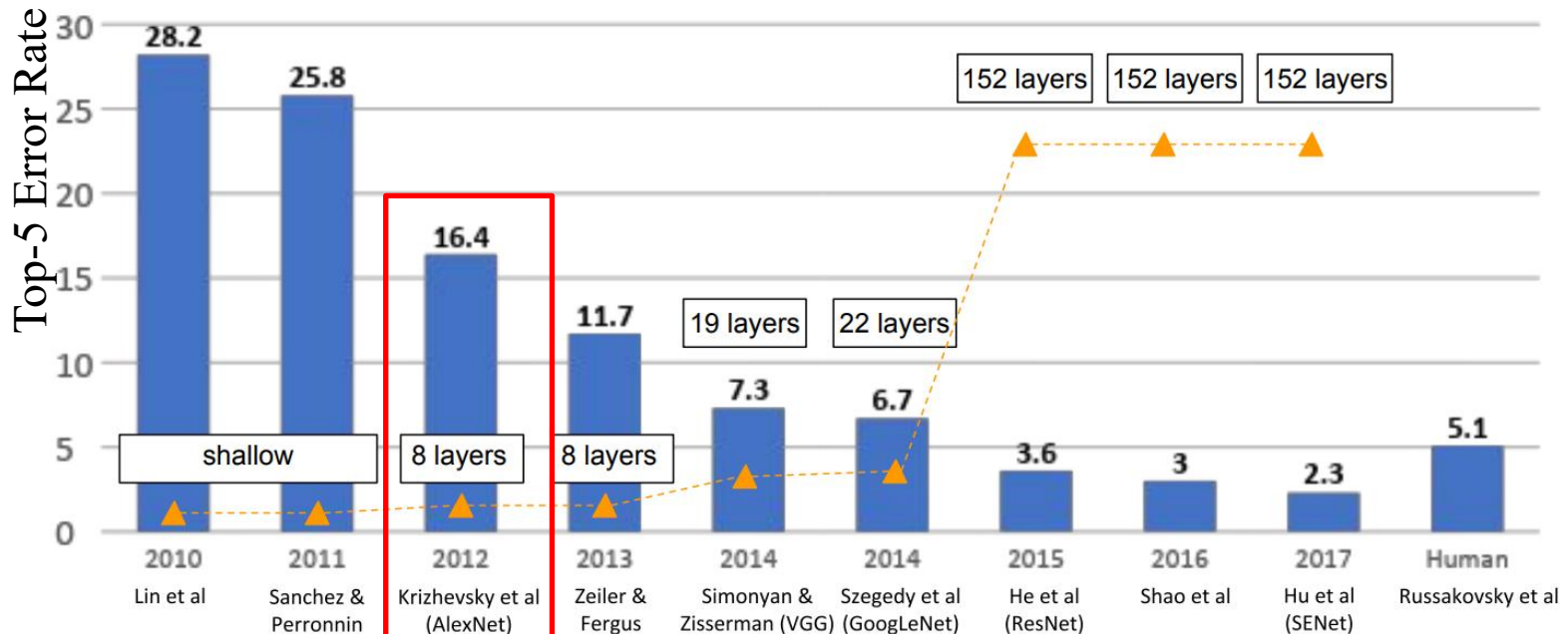

AlexNet

□ AlexNet

- 首次在ImageNet比赛中使用深度卷积神经网络
- 引入的一些技术被现代卷积神经网络设计一直沿用
 - ✓ ReLU
 - ✓ Data Augmentation
 - ✓ Dropout

Architecture:

CONV1
MAX POOL1
NORM1
CONV2
MAX POOL2
NORM2
CONV3
CONV4
CONV5
Max POOL3
FC6
FC7
FC8

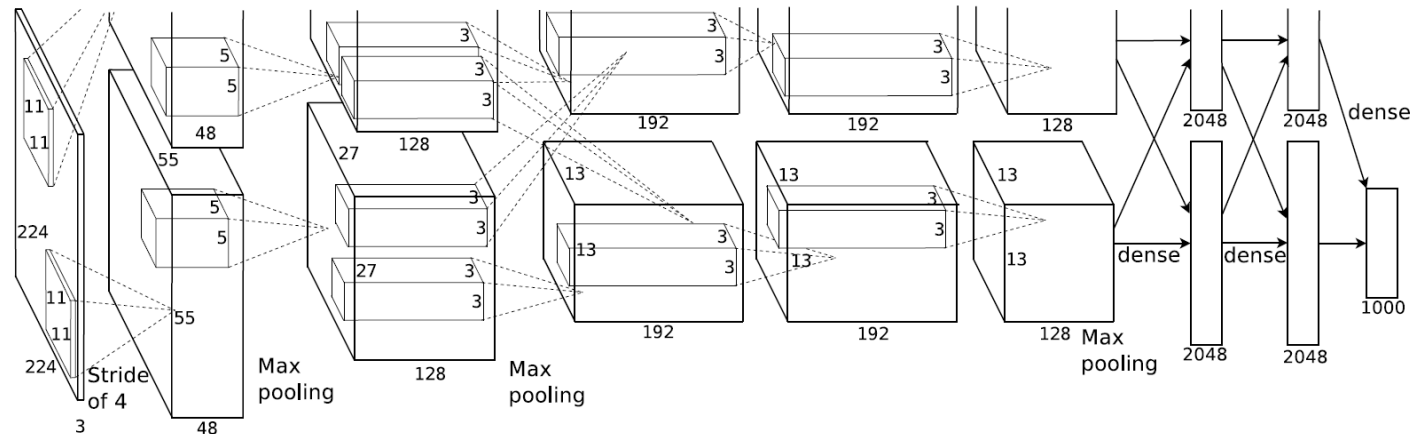

- A. Krizhevsky, I. Sutskever, and G. Hinton, “ImageNet classification with deep convolutional neural networks”. In NeurIPS, 2012.

AlexNet

□ AlexNet详细信息

Full (simplified) AlexNet architecture:

[227x227x3] INPUT

[55x55x96] **CONV1**: 96 11x11 filters at stride 4, pad 0

[27x27x96] **MAX POOL1**: 3x3 filters at stride 2

[27x27x96] **NORM1**: Normalization layer

[27x27x256] **CONV2**: 256 5x5 filters at stride 1, pad 2

[13x13x256] **MAX POOL2**: 3x3 filters at stride 2

[13x13x256] **NORM2**: Normalization layer

[13x13x384] **CONV3**: 384 3x3 filters at stride 1, pad 1

[13x13x384] **CONV4**: 384 3x3 filters at stride 1, pad 1

[13x13x256] **CONV5**: 256 3x3 filters at stride 1, pad 1

[6x6x256] **MAX POOL3**: 3x3 filters at stride 2

[4096] **FC6**: 4096 neurons

[4096] **FC7**: 4096 neurons

[1000] **FC8**: 1000 neurons (class scores)

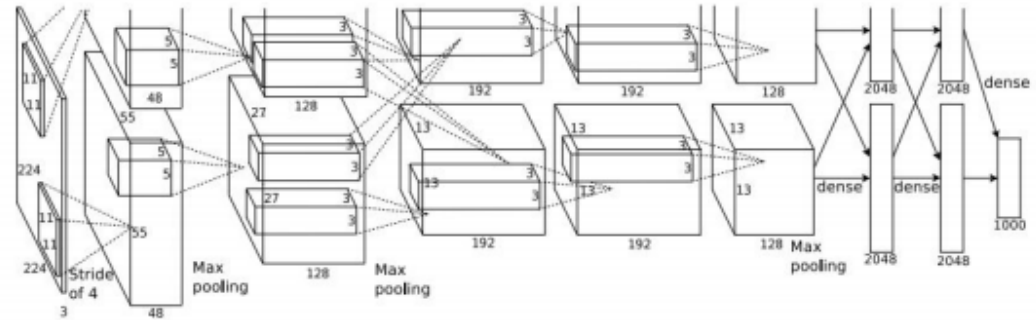

Details/Retrospectives:

- first use of ReLU
- used Norm layers (not common anymore)
- heavy data augmentation
- dropout 0.5
- batch size 128
- SGD Momentum 0.9
- Learning rate 1e-2, reduced by 10 manually when val accuracy plateaus
- L2 weight decay 5e-4
- 7 CNN ensemble: 18.2% -> 15.4%



AlexNet

□ 参数规模与计算复杂度

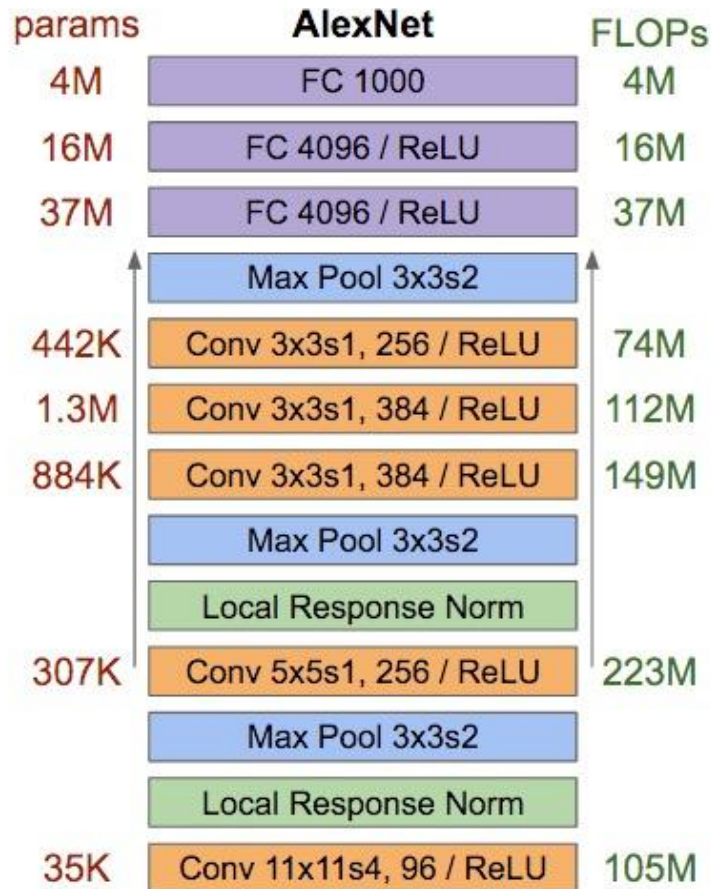

AlexNet

□ AlexNet中使用的学习策略

- Weight decay

$$\tilde{E}(w) = E(w) + \frac{\lambda}{2} w^T w$$

- Data augmentation

目的：扩充训练样本库

方法：水平翻转，crop图中部分区域

- Dropout

目的：防止过拟合，相当于指数级倍网络的组合

方法：在每次训练的迭代中，只会激活部分神经元

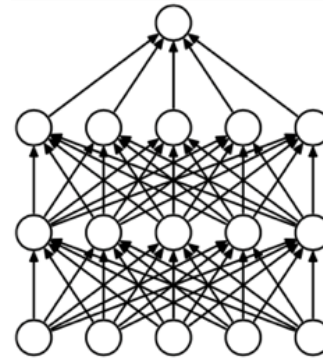

(a) Standard Neural Net

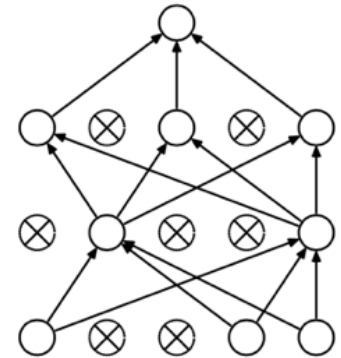

(b) After applying dropout.

AlexNet网络结构改进

□ AlexNet改进的主要方向

- 更深：增加网络的层数
- 更宽：增加每一级网络的卷积单元

□ ZFNet：微调AlexNet结构参数

- 将AlexNet中第一个 11×11 ，stride为4的卷积层，换成 7×7 ，stride为2的卷积层
- 将Conv3,4,5中的channel数增加到512,1024,512

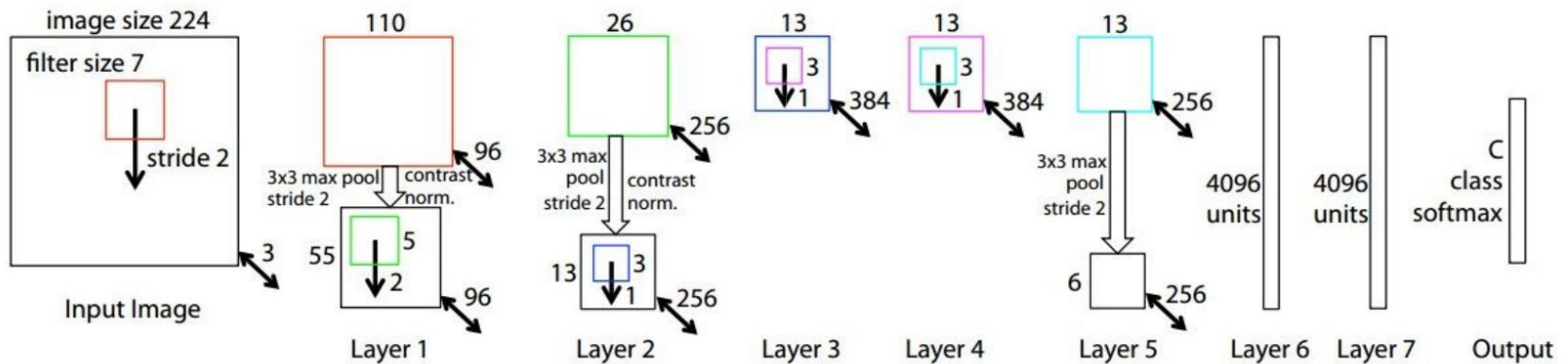

ZFNet

□ 超参数的改进在效果上得到了明显的体现

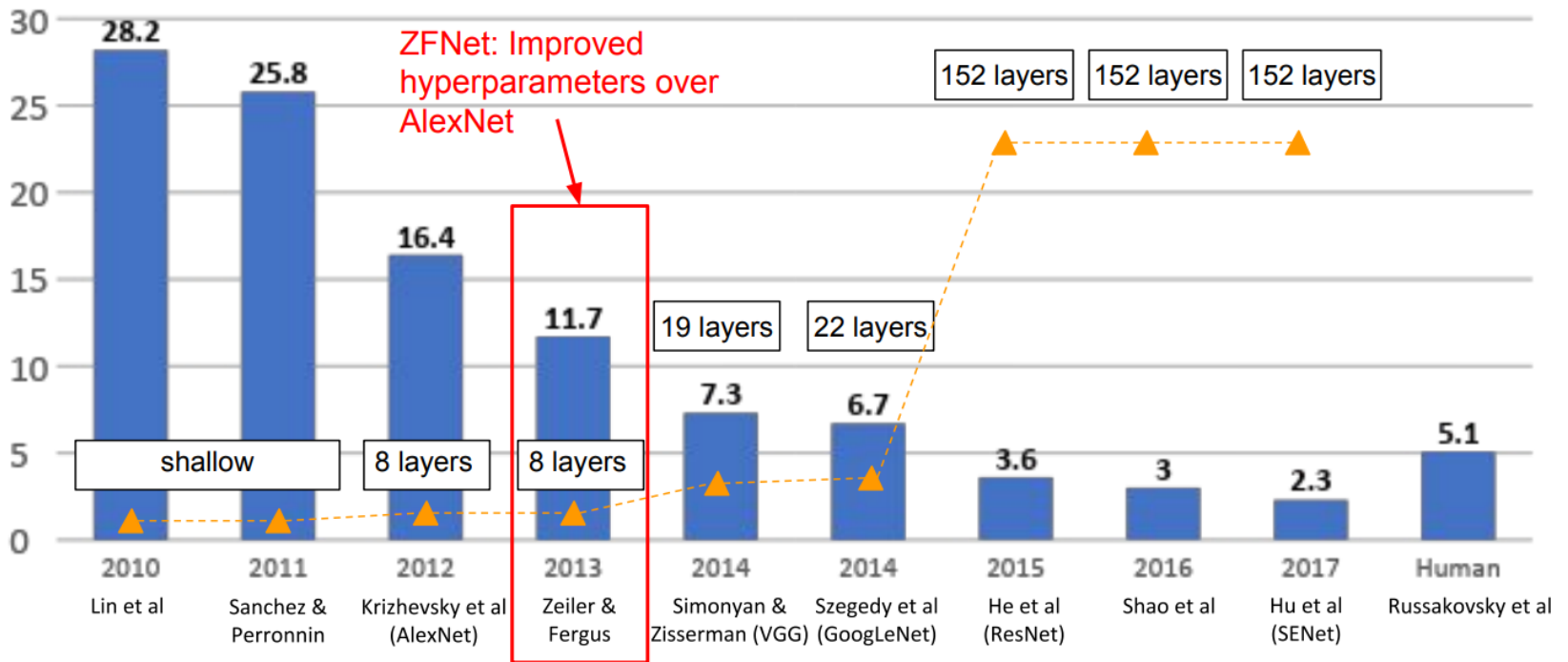

卷积神经网络特征可视化

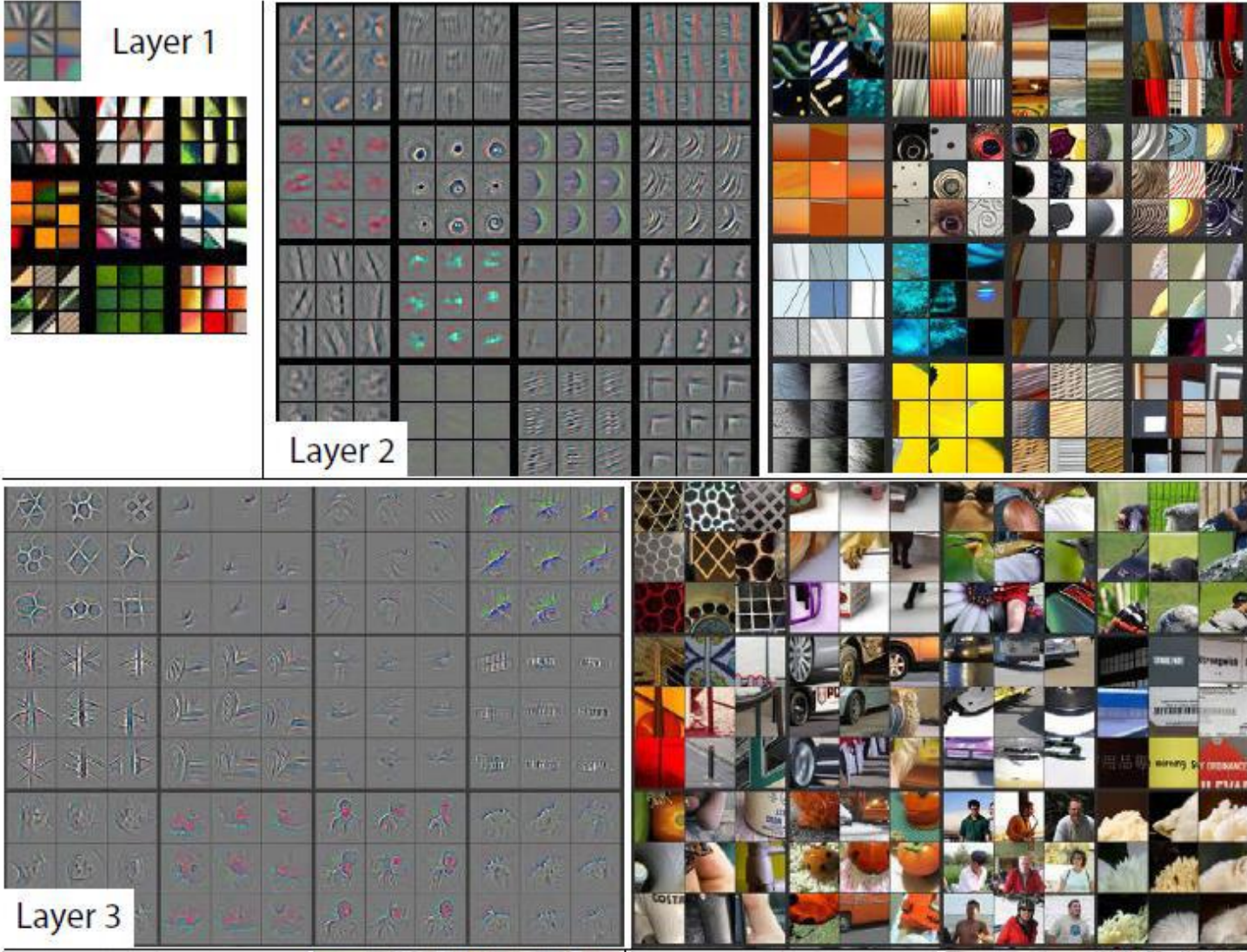

卷积神经网络特征可视化

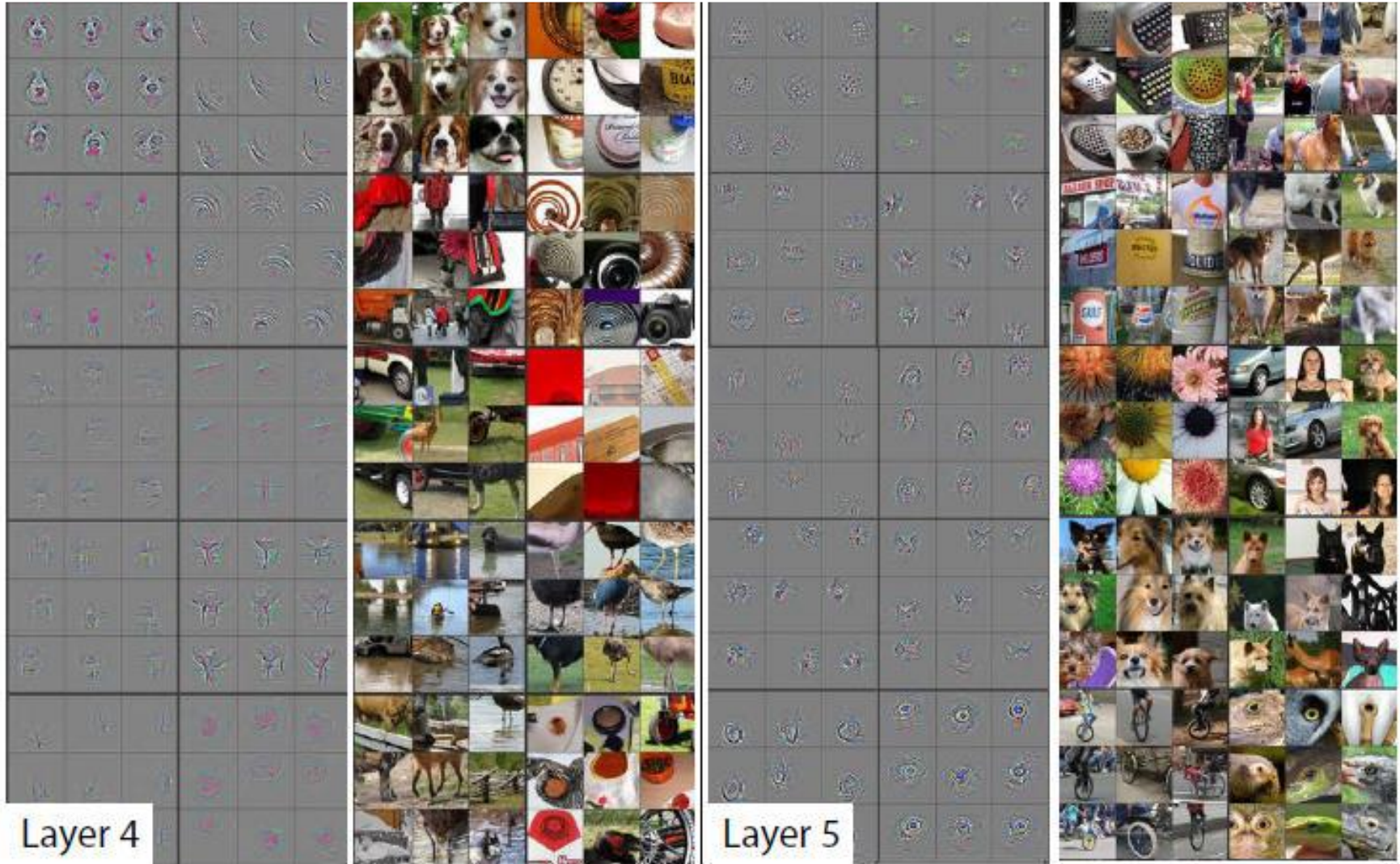

Layer 4

Layer 5

VGGNet

□ 主要思想

- 更小的卷积核
- 更深的网络结构

□ 与AlexNet的差异

- 从8层变为16-19层
- 卷积层大小均为 3×3 , stride均为1
- 下采样用 2×2 的 max pooling

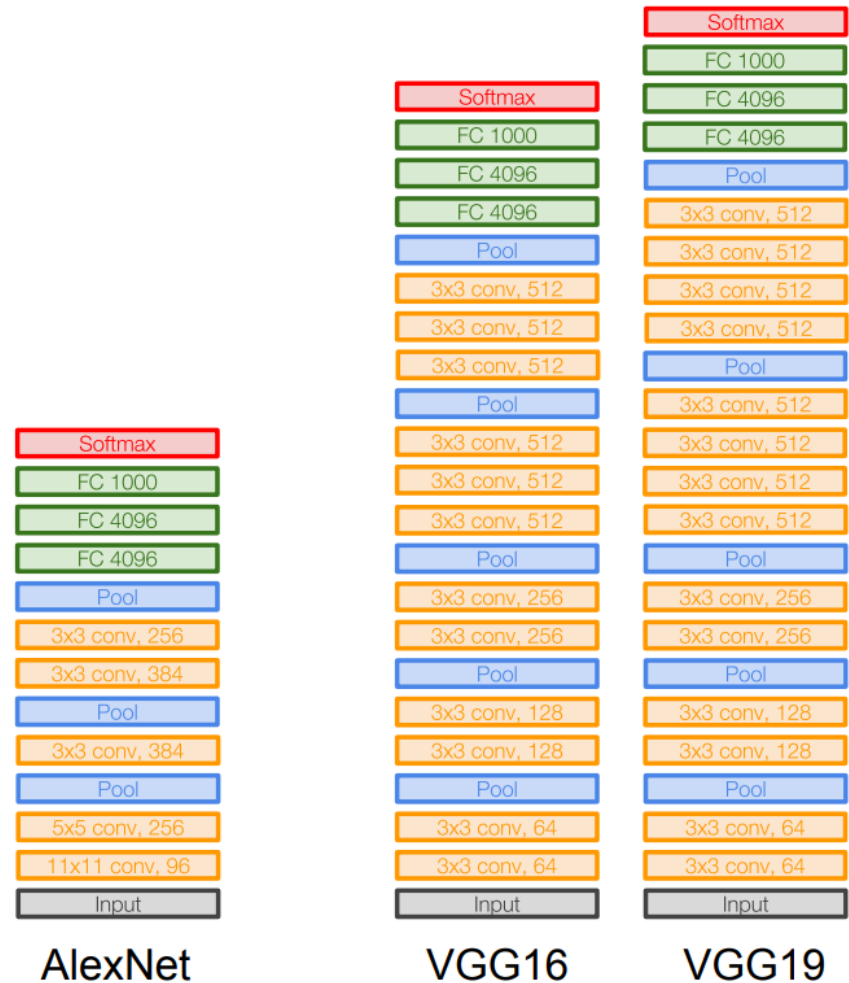

- K. Simonyan and A. Zisserman, “Very Deep Convolutional Networks for Large-Scale Image Recognition”. In ICLR, 2015.



VGGNet

□ 为什么使用更小的卷积层

■ 感受野的等效性

- ✓ 3个stride为1的 3×3 的卷积层对应的感受野，等效于1个 7×7 大小的卷积层

■ 等效感受野的情况下更少的参数（假设输入和输出的channel数量均为1）

- ✓ 3个 3×3 的卷积层的参数量： $3 \times 3^2 = 27$
- ✓ 1个 7×7 的卷积层的参数量： $1 \times 7^2 = 49$

■ 更深的结构与更多的非线性激活层带来更好的特征表达的能力



VGGNet

□ VGGNet的各种变种（D和E较为常用）

ConvNet Configuration					
A	A-LRN	B	C	D	E
11 weight layers	11 weight layers	13 weight layers	16 weight layers	16 weight layers	19 weight layers
input (224 × 224 RGB image)					
conv3-64	conv3-64 LRN	conv3-64 conv3-64	conv3-64 conv3-64	conv3-64 conv3-64	conv3-64 conv3-64
maxpool					
conv3-128	conv3-128	conv3-128 conv3-128	conv3-128 conv3-128	conv3-128 conv3-128	conv3-128 conv3-128
maxpool					
conv3-256 conv3-256	conv3-256 conv3-256	conv3-256 conv3-256	conv3-256 conv3-256 conv1-256	conv3-256 conv3-256 conv3-256	conv3-256 conv3-256 conv3-256 conv3-256
maxpool					
conv3-512 conv3-512	conv3-512 conv3-512	conv3-512 conv3-512	conv3-512 conv3-512 conv1-512	conv3-512 conv3-512 conv3-512	conv3-512 conv3-512 conv3-512 conv3-512
maxpool					
conv3-512 conv3-512	conv3-512 conv3-512	conv3-512 conv3-512	conv3-512 conv3-512 conv1-512	conv3-512 conv3-512 conv3-512	conv3-512 conv3-512 conv3-512 conv3-512
maxpool					
FC-4096					
FC-4096					
FC-1000					
soft-max					

GoogLeNet

- 更深的网络结构，更高的计算效率
 - 有22层，远深于AlexNet
 - Inception module (network within a network)
 - ✓ 不同大小的卷积层和池化层使inception结构具备不同的感受野

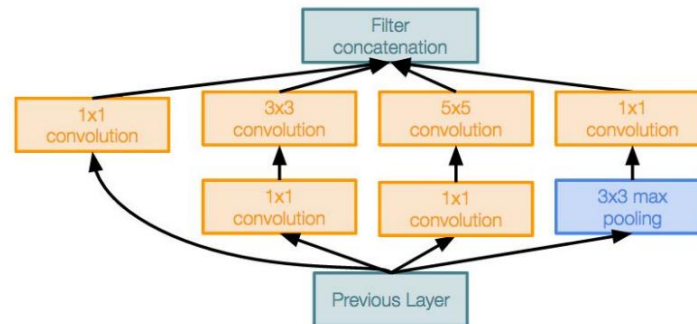

Inception module

- 没有全连接层，网络参数总量比AlexNet小12倍

GoogLeNet, VGGNet, AlexNet的对比让大家意识到，网络的学习能力不是主要取决于参数的多少，而是网络的深度

GoogLeNet

□ Inception module中的 1×1 卷积与bottleneck

- 直接使用下面左图的结构会带了大量的计算量
- Inception module的实际实现中，先通过 1×1 卷积进行降维，再通过不同感受野的卷积核，并把结果拼接到一起
- 这样子先通过降维进行操作，再还原回原来维度的结构我们称为bottleneck

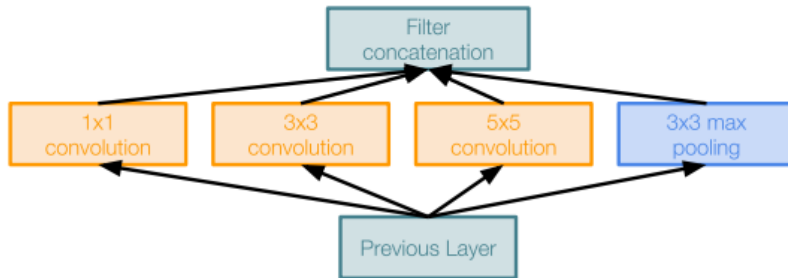

Naive Inception module

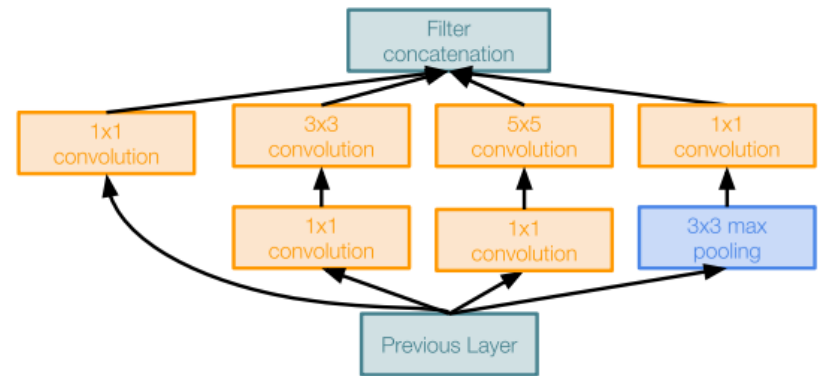

Inception module with dimension reduction

GoogLeNet

□ Auxiliary classification head

- 网络结构太深造成底层难以得到有效的训练，通过加入 auxiliary classification head 缓解这个问题

Full GoogLeNet architecture

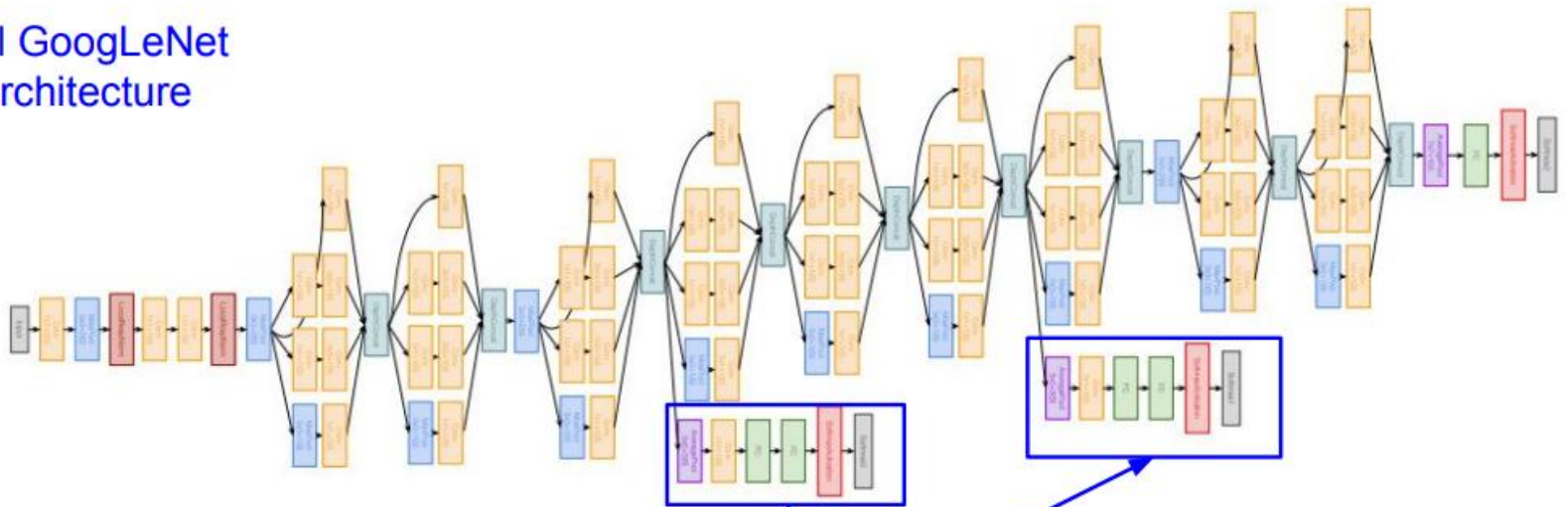

Auxiliary classification outputs to inject additional gradient at lower layers
(AvgPool-1x1Conv-FC-FC-Softmax)



VGGNet与GoogLeNet的性能

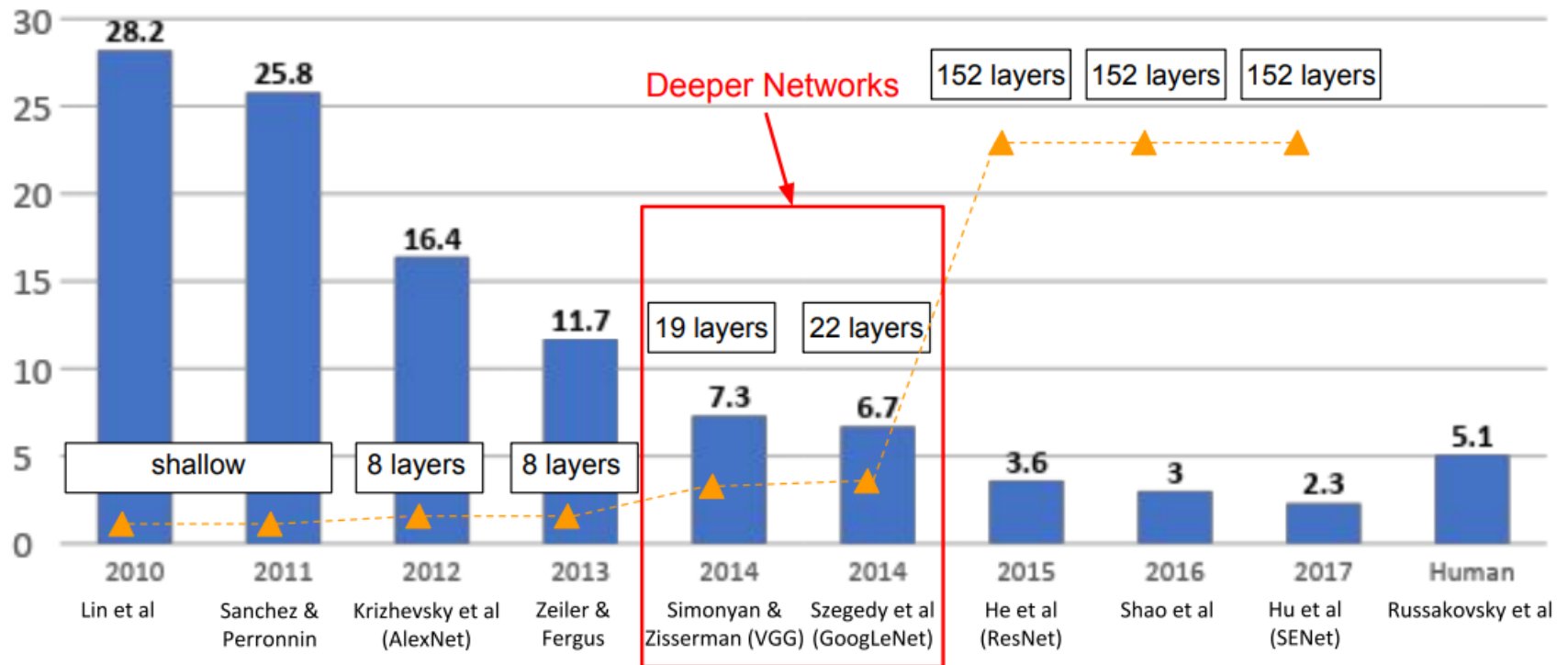

ResNet

□ Motivation

- Simply stacking more layers leads to higher training error
- Not all systems are similarly easy to optimize
- Hypothesis

It is easier to optimize the residual mapping than to optimize the original, unreferenced mapping.

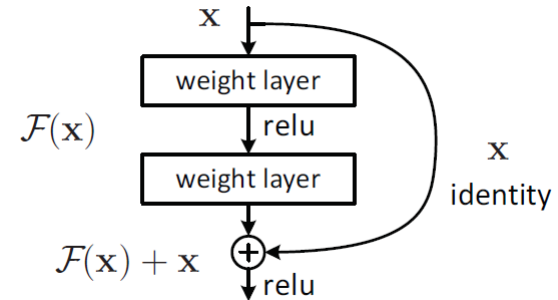
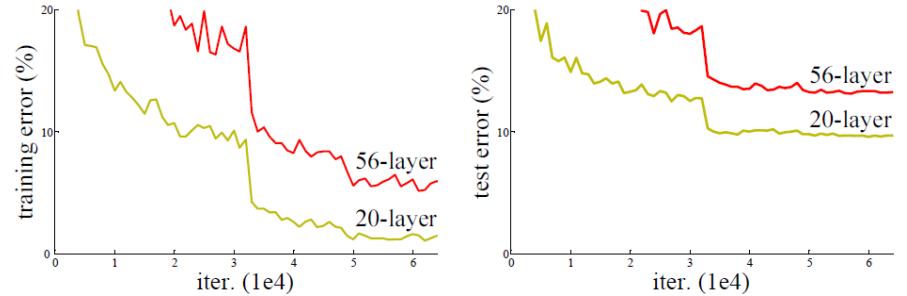

$$y = \mathcal{F}(\mathbf{x}, \{W_i\}) + \mathbf{x}.$$

$$y = \mathcal{F}(\mathbf{x}, \{W_i\}) + W_s \mathbf{x}.$$

- Kaiming He, Xiangyu Zhang, Shaoqing Ren, and Jian Sun. “Deep Residual Learning for Image Recognition”. In CVPR, 2016.

ResNet

□ Plain net 与 ResNet

- ResNet整体结构非常简洁
- 在不同层之间加入“shortcut”

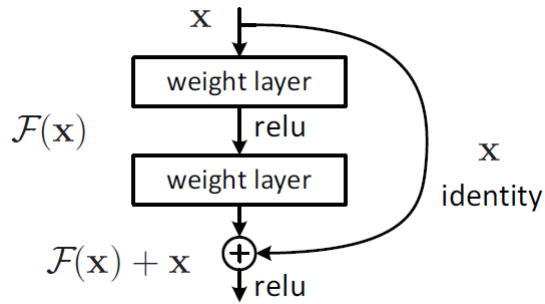

- 除stem cell (7 × 7卷积) 外均采用3 × 3卷积层
- 每当特征的空间分辨率减半时, filter的数量翻倍

plain net

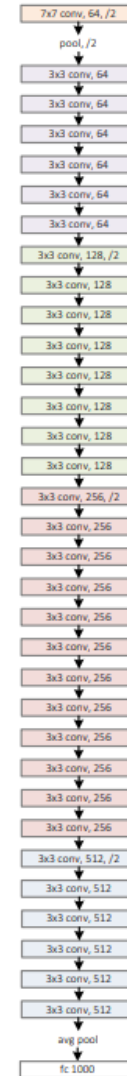

ResNet

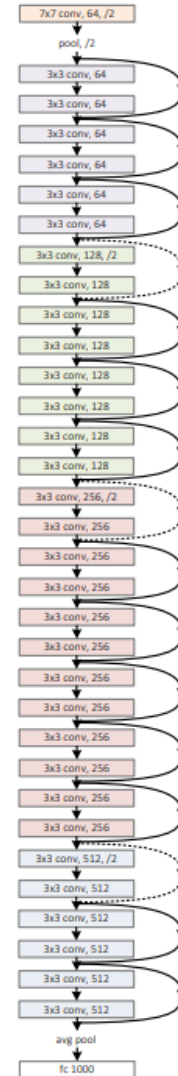



ResNet

□ ResNet不同深度的网络结构

layer name	output size	18-layer	34-layer	50-layer	101-layer	152-layer
conv1	112×112	7×7, 64, stride 2				
		3×3 max pool, stride 2				
conv2_x	56×56	$\begin{bmatrix} 3 \times 3, 64 \\ 3 \times 3, 64 \end{bmatrix} \times 2$	$\begin{bmatrix} 3 \times 3, 64 \\ 3 \times 3, 64 \end{bmatrix} \times 3$	$\begin{bmatrix} 1 \times 1, 64 \\ 3 \times 3, 64 \\ 1 \times 1, 256 \end{bmatrix} \times 3$	$\begin{bmatrix} 1 \times 1, 64 \\ 3 \times 3, 64 \\ 1 \times 1, 256 \end{bmatrix} \times 3$	$\begin{bmatrix} 1 \times 1, 64 \\ 3 \times 3, 64 \\ 1 \times 1, 256 \end{bmatrix} \times 3$
conv3_x	28×28	$\begin{bmatrix} 3 \times 3, 128 \\ 3 \times 3, 128 \end{bmatrix} \times 2$	$\begin{bmatrix} 3 \times 3, 128 \\ 3 \times 3, 128 \end{bmatrix} \times 4$	$\begin{bmatrix} 1 \times 1, 128 \\ 3 \times 3, 128 \\ 1 \times 1, 512 \end{bmatrix} \times 4$	$\begin{bmatrix} 1 \times 1, 128 \\ 3 \times 3, 128 \\ 1 \times 1, 512 \end{bmatrix} \times 4$	$\begin{bmatrix} 1 \times 1, 128 \\ 3 \times 3, 128 \\ 1 \times 1, 512 \end{bmatrix} \times 8$
conv4_x	14×14	$\begin{bmatrix} 3 \times 3, 256 \\ 3 \times 3, 256 \end{bmatrix} \times 2$	$\begin{bmatrix} 3 \times 3, 256 \\ 3 \times 3, 256 \end{bmatrix} \times 6$	$\begin{bmatrix} 1 \times 1, 256 \\ 3 \times 3, 256 \\ 1 \times 1, 1024 \end{bmatrix} \times 6$	$\begin{bmatrix} 1 \times 1, 256 \\ 3 \times 3, 256 \\ 1 \times 1, 1024 \end{bmatrix} \times 23$	$\begin{bmatrix} 1 \times 1, 256 \\ 3 \times 3, 256 \\ 1 \times 1, 1024 \end{bmatrix} \times 36$
conv5_x	7×7	$\begin{bmatrix} 3 \times 3, 512 \\ 3 \times 3, 512 \end{bmatrix} \times 2$	$\begin{bmatrix} 3 \times 3, 512 \\ 3 \times 3, 512 \end{bmatrix} \times 3$	$\begin{bmatrix} 1 \times 1, 512 \\ 3 \times 3, 512 \\ 1 \times 1, 2048 \end{bmatrix} \times 3$	$\begin{bmatrix} 1 \times 1, 512 \\ 3 \times 3, 512 \\ 1 \times 1, 2048 \end{bmatrix} \times 3$	$\begin{bmatrix} 1 \times 1, 512 \\ 3 \times 3, 512 \\ 1 \times 1, 2048 \end{bmatrix} \times 3$
	1×1	average pool, 1000-d fc, softmax				
FLOPs		1.8×10^9	3.6×10^9	3.8×10^9	7.6×10^9	11.3×10^9

ResNet

□ 在ImageNet上的训练过程

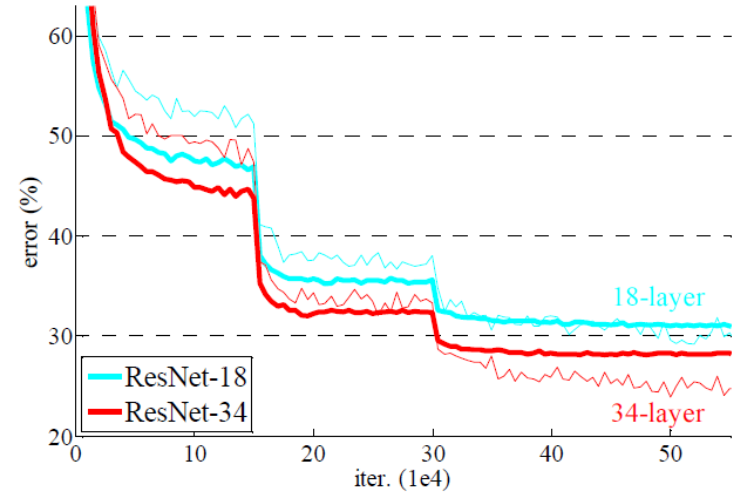
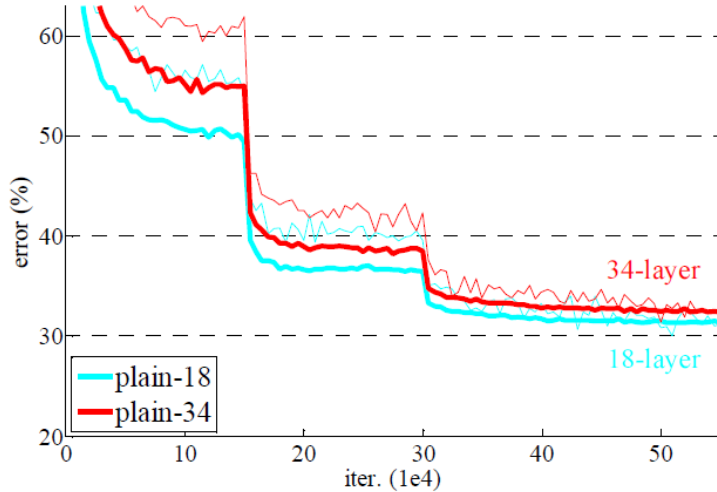

Error rates on ImageNet validation

method	top-1 err.	top-5 err.
VGG [41] (ILSVRC'14)	-	8.43 [†]
GoogLeNet [44] (ILSVRC'14)	-	7.89
VGG [41] (v5)	24.4	7.1
PReLU-net [13]	21.59	5.71
BN-inception [16]	21.99	5.81
ResNet-34 B	21.84	5.71
ResNet-34 C	21.53	5.60
ResNet-50	20.74	5.25
ResNet-101	19.87	4.60
ResNet-152	19.38	4.49

Error rates (%) of ensembles

method	top-5 err. (test)
VGG [41] (ILSVRC'14)	7.32
GoogLeNet [44] (ILSVRC'14)	6.66
VGG [41] (v5)	6.8
PReLU-net [13]	4.94
BN-inception [16]	4.82
ResNet (ILSVRC'15)	3.57

图像分类: DenseNet

- Key idea
 - Introduce direct connections from any layer to all subsequent layers
- The l -th layer receives the feature-maps of all preceding layers

$$\mathbf{x}_l = H_l([\mathbf{x}_0, \mathbf{x}_1, \dots, \mathbf{x}_{l-1}])$$

$[\mathbf{x}_0, \mathbf{x}_1, \dots, \mathbf{x}_{l-1}]$: the concatenation of the feature-maps produced in layers

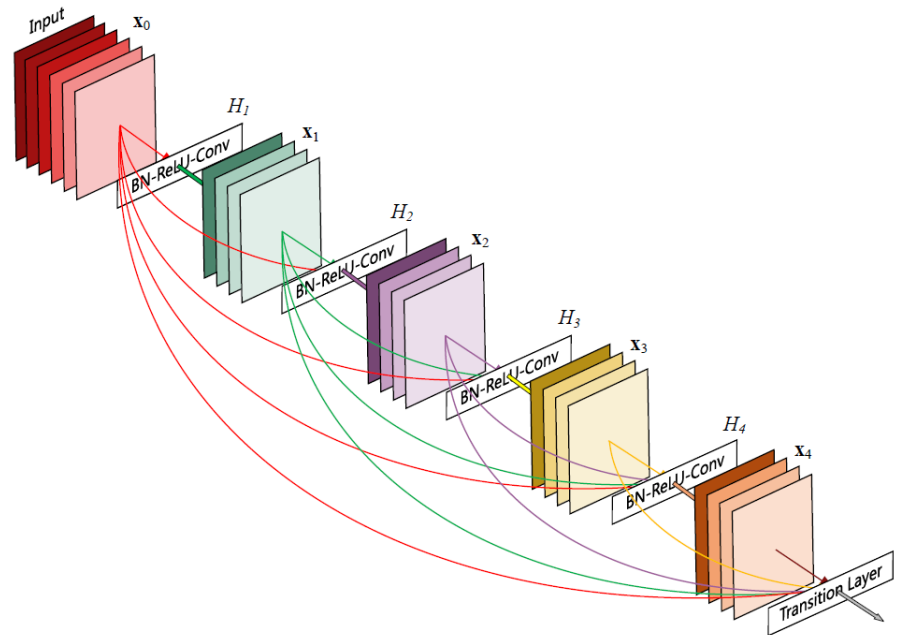

- G. Huang, Z. Liu, L. Maaten, and K. Q. Weinberger. “Densely Connected Convolutional Networks”. In CVPR, 2017.

图像分类: DenseNet

□ Framework illustration: a deep DenseNet with three dense blocks

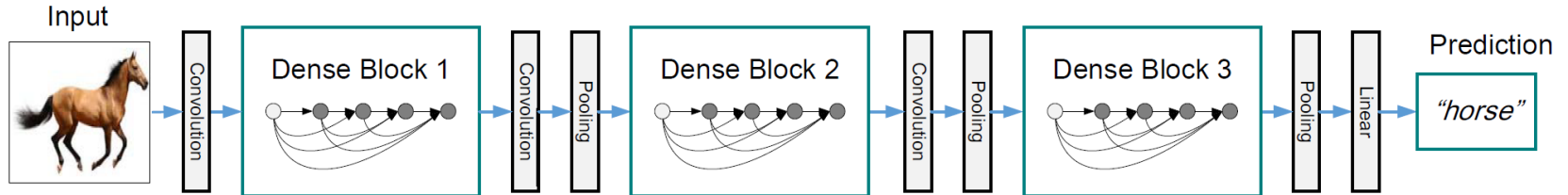

DenseNet architectures for ImageNet

Layers	Output Size	DenseNet-121($k = 32$)	DenseNet-169($k = 32$)	DenseNet-201($k = 32$)	DenseNet-161($k = 48$)
Convolution	112×112	7×7 conv, stride 2			
Pooling	56×56	3×3 max pool, stride 2			
Dense Block (1)	56×56	$\begin{bmatrix} 1 \times 1 \text{ conv} \\ 3 \times 3 \text{ conv} \end{bmatrix} \times 6$	$\begin{bmatrix} 1 \times 1 \text{ conv} \\ 3 \times 3 \text{ conv} \end{bmatrix} \times 6$	$\begin{bmatrix} 1 \times 1 \text{ conv} \\ 3 \times 3 \text{ conv} \end{bmatrix} \times 6$	$\begin{bmatrix} 1 \times 1 \text{ conv} \\ 3 \times 3 \text{ conv} \end{bmatrix} \times 6$
Transition Layer (1)	56×56	1×1 conv			
	28×28	2×2 average pool, stride 2			
Dense Block (2)	28×28	$\begin{bmatrix} 1 \times 1 \text{ conv} \\ 3 \times 3 \text{ conv} \end{bmatrix} \times 12$	$\begin{bmatrix} 1 \times 1 \text{ conv} \\ 3 \times 3 \text{ conv} \end{bmatrix} \times 12$	$\begin{bmatrix} 1 \times 1 \text{ conv} \\ 3 \times 3 \text{ conv} \end{bmatrix} \times 12$	$\begin{bmatrix} 1 \times 1 \text{ conv} \\ 3 \times 3 \text{ conv} \end{bmatrix} \times 12$
Transition Layer (2)	28×28	1×1 conv			
	14×14	2×2 average pool, stride 2			
Dense Block (3)	14×14	$\begin{bmatrix} 1 \times 1 \text{ conv} \\ 3 \times 3 \text{ conv} \end{bmatrix} \times 24$	$\begin{bmatrix} 1 \times 1 \text{ conv} \\ 3 \times 3 \text{ conv} \end{bmatrix} \times 32$	$\begin{bmatrix} 1 \times 1 \text{ conv} \\ 3 \times 3 \text{ conv} \end{bmatrix} \times 48$	$\begin{bmatrix} 1 \times 1 \text{ conv} \\ 3 \times 3 \text{ conv} \end{bmatrix} \times 36$
Transition Layer (3)	14×14	1×1 conv			
	7×7	2×2 average pool, stride 2			
Dense Block (4)	7×7	$\begin{bmatrix} 1 \times 1 \text{ conv} \\ 3 \times 3 \text{ conv} \end{bmatrix} \times 16$	$\begin{bmatrix} 1 \times 1 \text{ conv} \\ 3 \times 3 \text{ conv} \end{bmatrix} \times 32$	$\begin{bmatrix} 1 \times 1 \text{ conv} \\ 3 \times 3 \text{ conv} \end{bmatrix} \times 32$	$\begin{bmatrix} 1 \times 1 \text{ conv} \\ 3 \times 3 \text{ conv} \end{bmatrix} \times 24$
Classification Layer	1×1	7×7 global average pool			
		1000D fully-connected, softmax			

图像分类: DenseNet

Comparison with ResNet

- 参数少，计算复杂度低，但精度相当
- 对前面层的响应图的concatenate的操作非常消耗显存
- 泛化能力不好且缺少相应code base的支撑

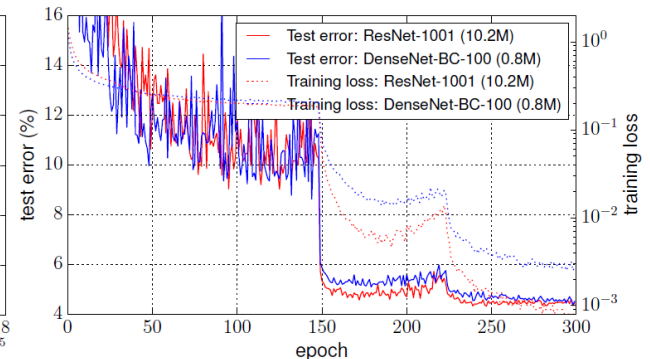
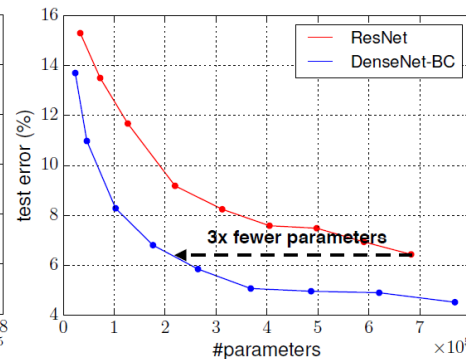
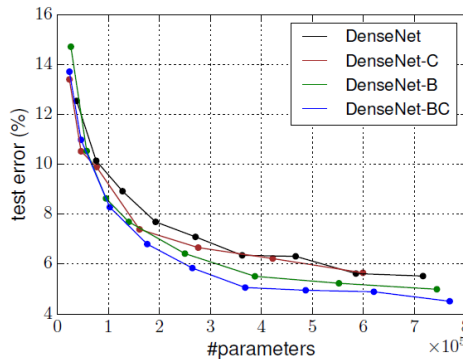
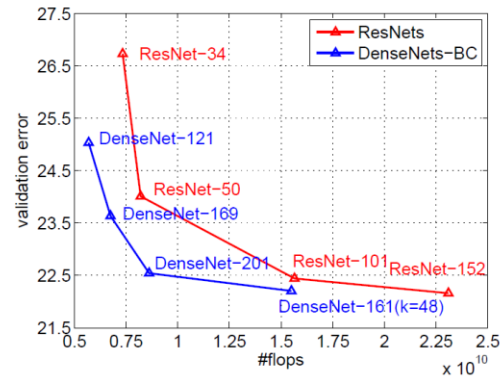
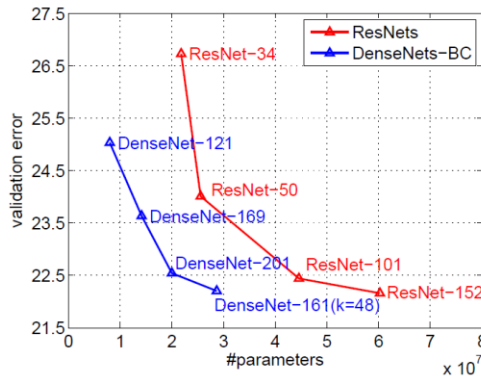

MobileNet

- Goal: *efficiently trade off between latency and accuracy*
 - Build very small, low latency models that can be easily matched to the design requirements for mobile and embedded vision applications
- Depthwise Separable Convolution

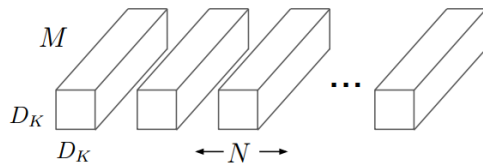

(a) Standard Convolution Filters

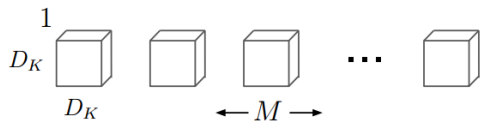

(b) Depthwise Convolutional Filters

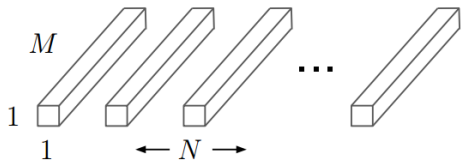

(c) 1×1 Convolutional Filters called Pointwise Convolution in the context of Depthwise Separable Convolution

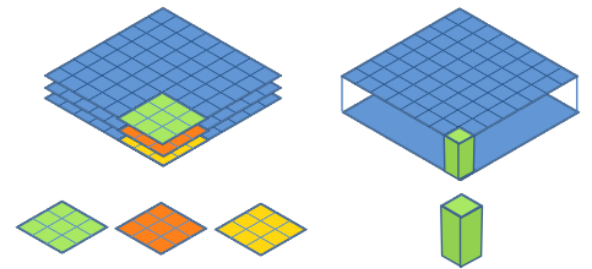

Depthwise Convolutional Filters Pointwise Convolutional Filters

Figure 2. Depthwise separable convolution.

$$\begin{aligned}
 & \frac{D_K \cdot D_K \cdot M \cdot D_F \cdot D_F + M \cdot N \cdot D_F \cdot D_F}{D_K \cdot D_K \cdot M \cdot N \cdot D_F \cdot D_F} \\
 &= \frac{1}{N} + \frac{1}{D_K^2}
 \end{aligned}$$

Figure 1. Standard convolution vs separable convolution.

MobileNet

□ Architecture

Table 1. MobileNet Body Architecture

Type / Stride	Filter Shape	Input Size
Conv / s2	$3 \times 3 \times 3 \times 32$	$224 \times 224 \times 3$
Conv dw / s1	$3 \times 3 \times 32$ dw	$112 \times 112 \times 32$
Conv / s1	$1 \times 1 \times 32 \times 64$	$112 \times 112 \times 32$
Conv dw / s2	$3 \times 3 \times 64$ dw	$112 \times 112 \times 64$
Conv / s1	$1 \times 1 \times 64 \times 128$	$56 \times 56 \times 64$
Conv dw / s1	$3 \times 3 \times 128$ dw	$56 \times 56 \times 128$
Conv / s1	$1 \times 1 \times 128 \times 128$	$56 \times 56 \times 128$
Conv dw / s2	$3 \times 3 \times 128$ dw	$56 \times 56 \times 128$
Conv / s1	$1 \times 1 \times 128 \times 256$	$28 \times 28 \times 128$
Conv dw / s1	$3 \times 3 \times 256$ dw	$28 \times 28 \times 256$
Conv / s1	$1 \times 1 \times 256 \times 256$	$28 \times 28 \times 256$
Conv dw / s2	$3 \times 3 \times 256$ dw	$28 \times 28 \times 256$
Conv / s1	$1 \times 1 \times 256 \times 512$	$14 \times 14 \times 256$
$5 \times$ Conv dw / s1	$3 \times 3 \times 512$ dw	$14 \times 14 \times 512$
Conv / s1	$1 \times 1 \times 512 \times 512$	$14 \times 14 \times 512$
Conv dw / s2	$3 \times 3 \times 512$ dw	$14 \times 14 \times 512$
Conv / s1	$1 \times 1 \times 512 \times 1024$	$7 \times 7 \times 512$
Conv dw / s2	$3 \times 3 \times 1024$ dw	$7 \times 7 \times 1024$
Conv / s1	$1 \times 1 \times 1024 \times 1024$	$7 \times 7 \times 1024$
Avg Pool / s1	Pool 7×7	$7 \times 7 \times 1024$
FC / s1	1024×1000	$1 \times 1 \times 1024$
Softmax / s1	Classifier	$1 \times 1 \times 1000$

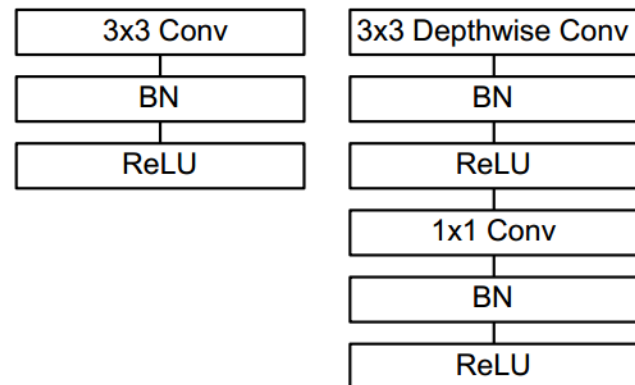

Figure 3. Left: Standard convolutional layer with batchnorm and ReLU. Right: Depthwise Separable convolutions with Depthwise and Pointwise layers followed by batchnorm and ReLU.

Table 4. Depthwise Separable vs Full Convolution MobileNet

Model	ImageNet Accuracy	Million Mult-Adds	Million Parameters
Conv MobileNet	71.7%	4866	29.3
MobileNet	70.6%	569	4.2



MobileNet

□ Performance

Table 8. MobileNet Comparison to Popular Models

Model	ImageNet Accuracy	Million Mult-Adds	Million Parameters
1.0 MobileNet-224	70.6%	569	4.2
GoogLeNet	69.8%	1550	6.8
VGG 16	71.5%	15300	138

Table 9. Smaller MobileNet Comparison to Popular Models

Model	ImageNet Accuracy	Million Mult-Adds	Million Parameters
0.50 MobileNet-160	60.2%	76	1.32
Squeezenet	57.5%	1700	1.25
AlexNet	57.2%	720	60



课堂测试

- 1. 简述反向传播算法的基本原理，并说明为什么深层网络容易出现梯度消失或梯度爆炸问题。
- 2. 比较 Batch Normalization 和 Layer Normalization 的异同点，并说明各自适用的场景。



深度学习基础

- 深度前馈网络
- 卷积神经网络
- 循环神经网络
 - RNN
 - LSTM
 - GRU
- Transformer网络

循环神经网络

□ 序列处理

one to one

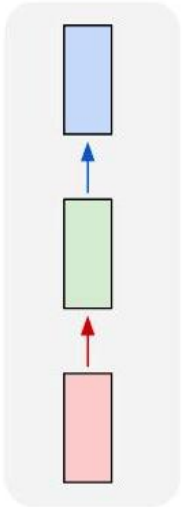

one to many

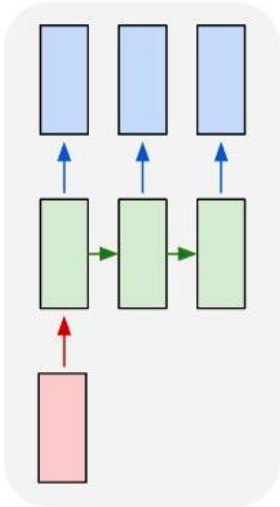

many to one

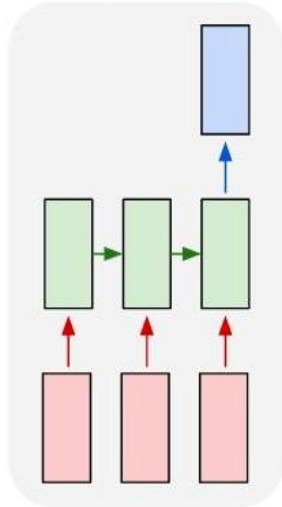

many to many

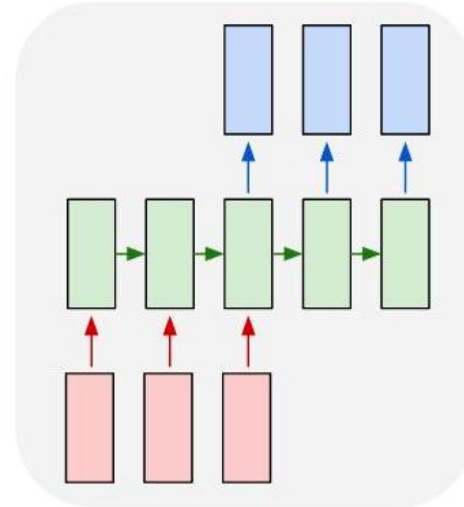

many to many

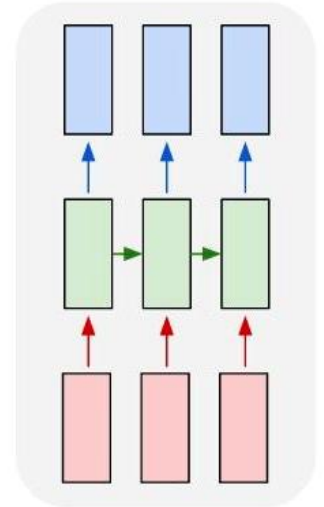

循环神经网络

□ Recurrent neural network (RNN)

- 输入 $x = \{x_1, x_2, \dots, x_N\}$ 是一个序列
- RNN 递归地处理输入信号

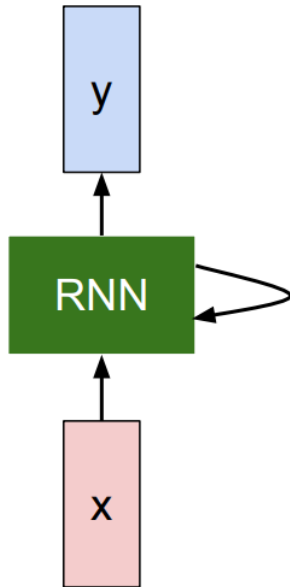

$$h_t = f_W(h_{t-1}, x_t)$$

new state some function with parameters W old state input vector at some time step

$$y_t = f_{W_{hy}}(h_t)$$

output another function with parameters W_o new state

循环神经网络

□ Vanilla RNN

- RNN的一种最简单的形式，具有单个隐藏单元
- 存在的问题
 - ✓ 梯度消失和梯度爆炸
 - RNN的权值矩阵循环相乘导致的
 - ✓ 长期依赖
 - 之前比较长的时间片的特征被覆盖/遗忘
 - ✓ 难并行

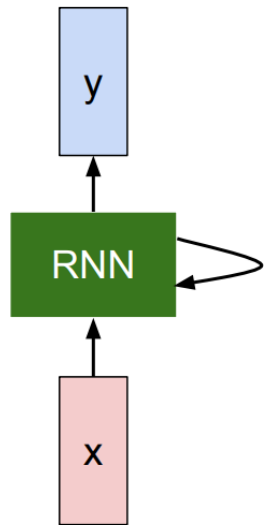

$$h_t = f_W(h_{t-1}, x_t)$$



$$h_t = \tanh(W_{hh}h_{t-1} + W_{xh}x_t)$$

$$y_t = W_{hy}h_t$$

循环神经网络

□ Vanilla RNN的计算图

- 序列输入，单个输出的形式

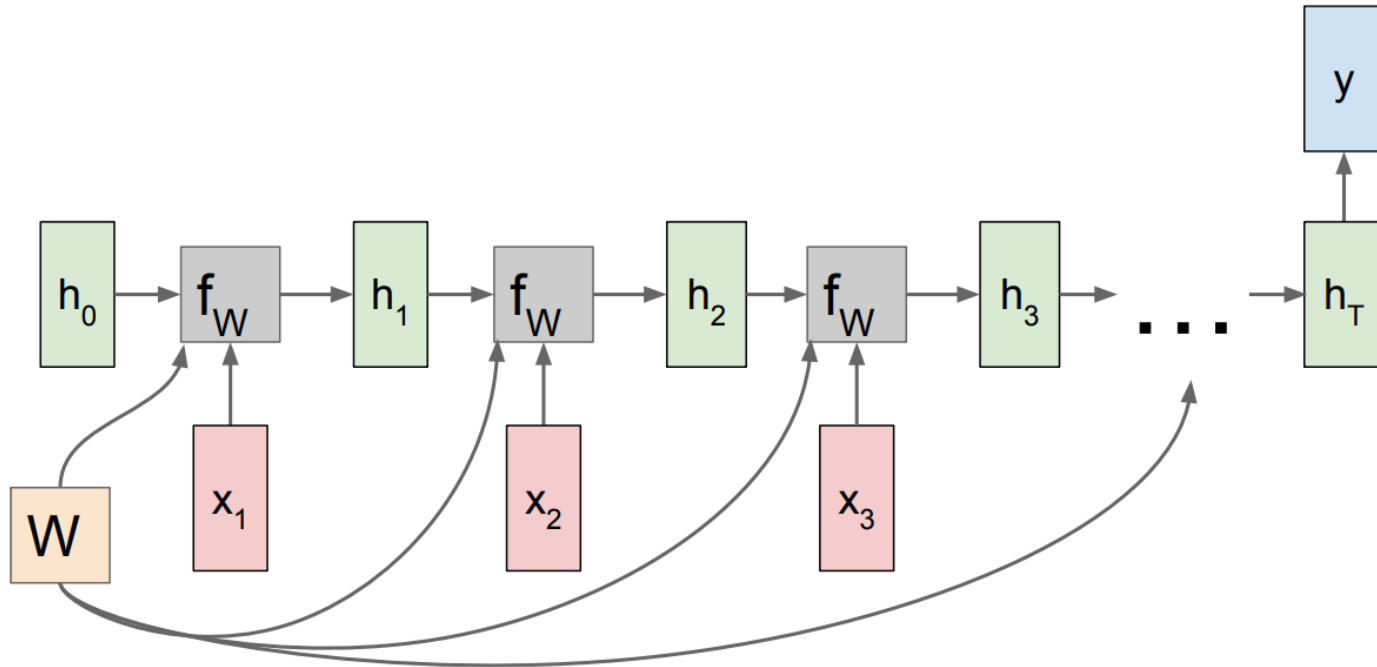

循环神经网络

□ Vanilla RNN的计算图

- 序列输入，序列输出的形式

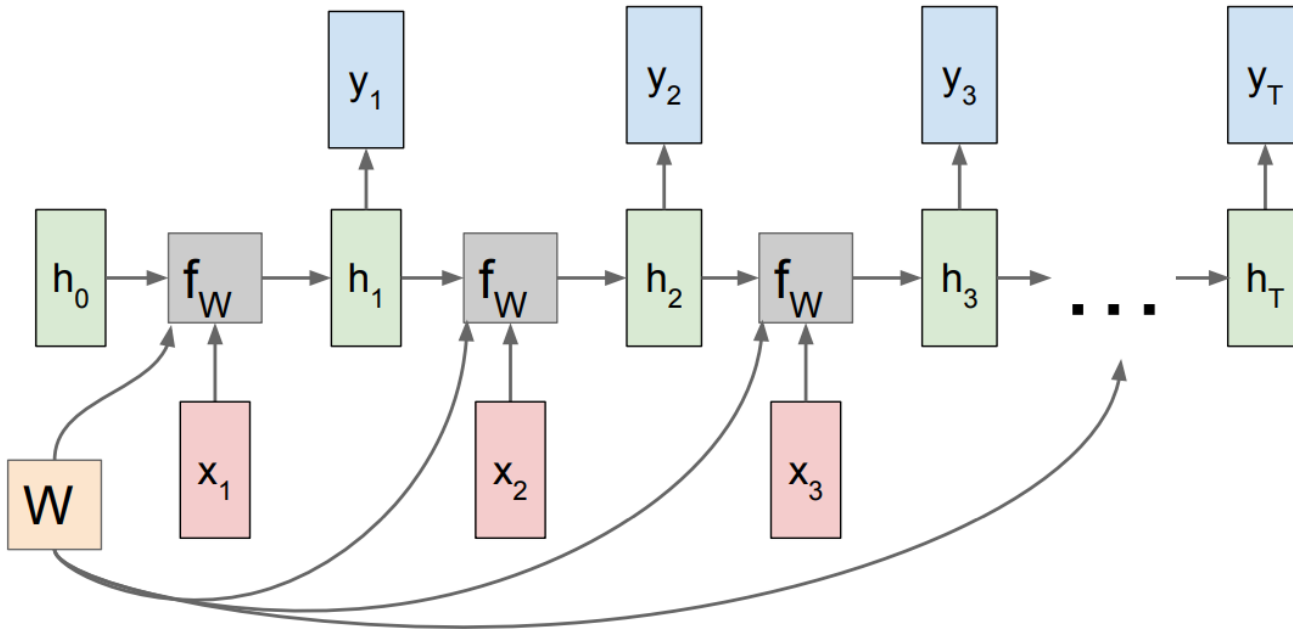

网络参数 W 在每个时刻都是共享的

循环神经网络

- Sequence to Sequence:
 - Many-to-one + One-to-many

Many to one: Encode input sequence in a single vector

One to many: Produce output sequence from single input vector

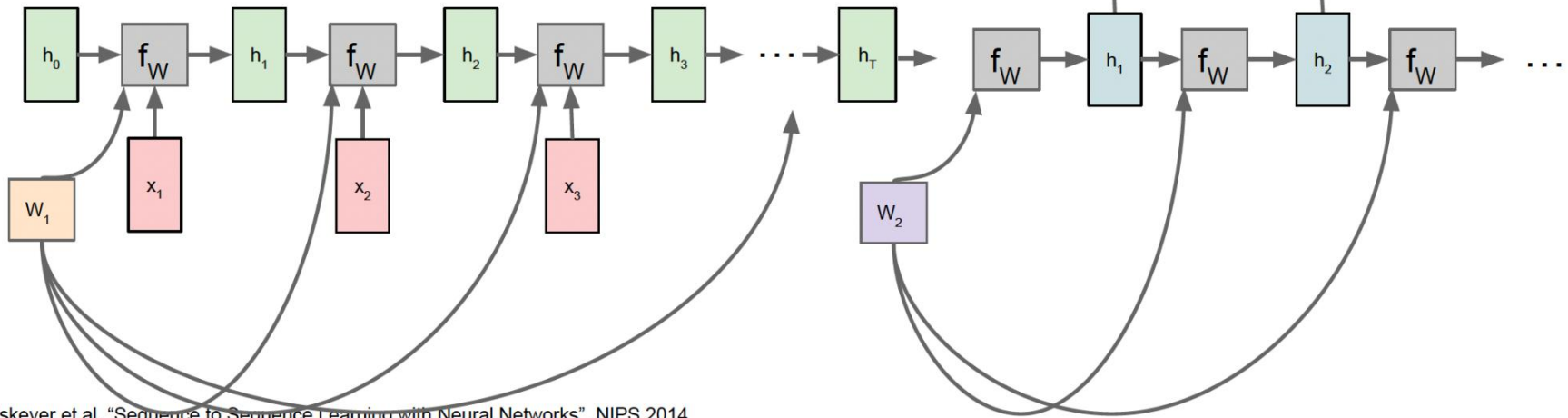

循环神经网络

□ Variants of RNN: LSTM

- 可以解决长序列训练过程中的**梯度消失**和**梯度爆炸**问题，并缓解**长时依赖**问题
- Cell state（**单元状态**）：用于“记忆”当前的状态，上面包含记忆的删除、更新等
- 遗忘门 f_t ，输入门 i_t ，输出门 o_t

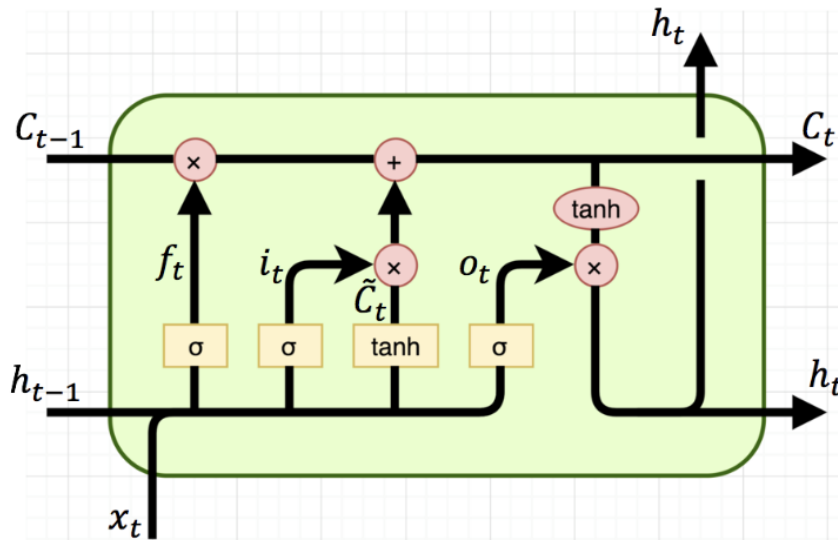

$$f_t = \sigma(W_f \cdot [h_{t-1}, x_t] + b_f)$$

$$i_t = \sigma(W_i \cdot [h_{t-1}, x_t] + b_i)$$

$$o_t = \sigma(W_o \cdot [h_{t-1}, x_t] + b_o)$$

$$\tilde{C}_t = \tanh(W_c \cdot [h_{t-1}, x_t] + b_c)$$

$$C_t = f_t \odot C_{t-1} + i_t \odot \tilde{C}_t$$

$$h_t = o_t \odot \tanh(C_t)$$

循环神经网络

□ Variants of RNN: GRU

- A simplified version of LSTM
- 遗忘门和输入门统一为更新门
- 移除独立的细胞状态

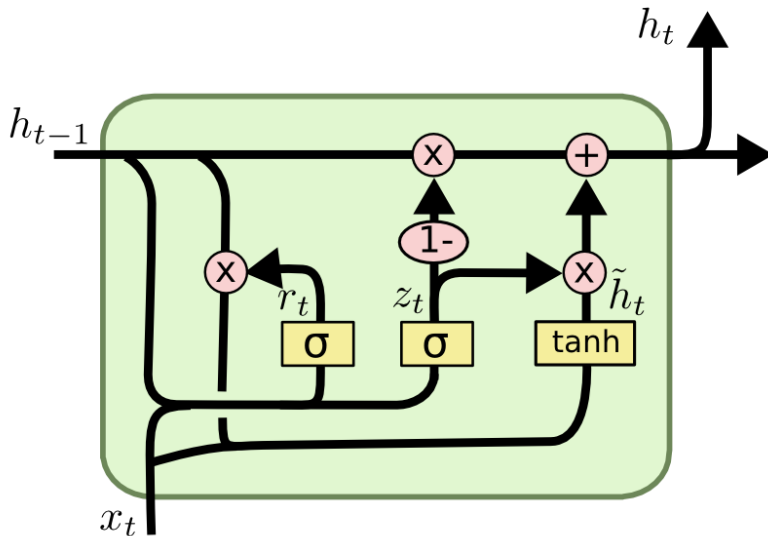

$$z_t = \sigma(W_z \cdot [h_{t-1}, x_t])$$

$$r_t = \sigma(W_r \cdot [h_{t-1}, x_t])$$

$$\tilde{h}_t = \tanh(W \cdot [r_t * h_{t-1}, x_t])$$

$$h_t = (1 - z_t) * h_{t-1} + z_t * \tilde{h}_t$$



深度学习基础

- 深度前馈网络
- 卷积神经网络
- 循环神经网络
- Transformer网络
 - RNN+注意力
 - 注意力机制
 - Transformer

基于RNN的序列到序列模型

Input: Sequence x_1, \dots, x_T
Output: Sequence y_1, \dots, y_T

Decoder: $s_t = g_U(y_{t-1}, s_{t-1}, c)$

Encoder: $h_t = f_W(x_t, h_{t-1})$

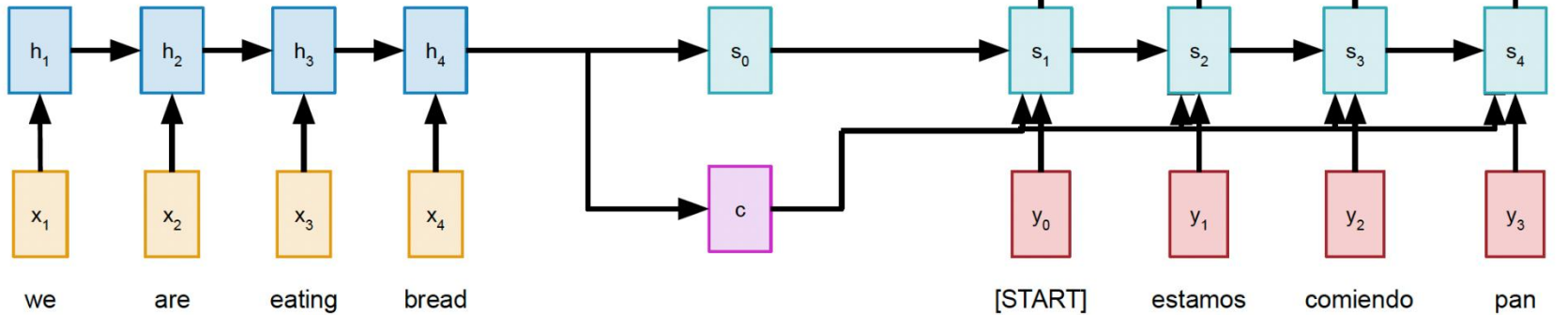

问题：输入序列的信息被压缩到单个向量

RNN+注意力

□ 引入注意力机制

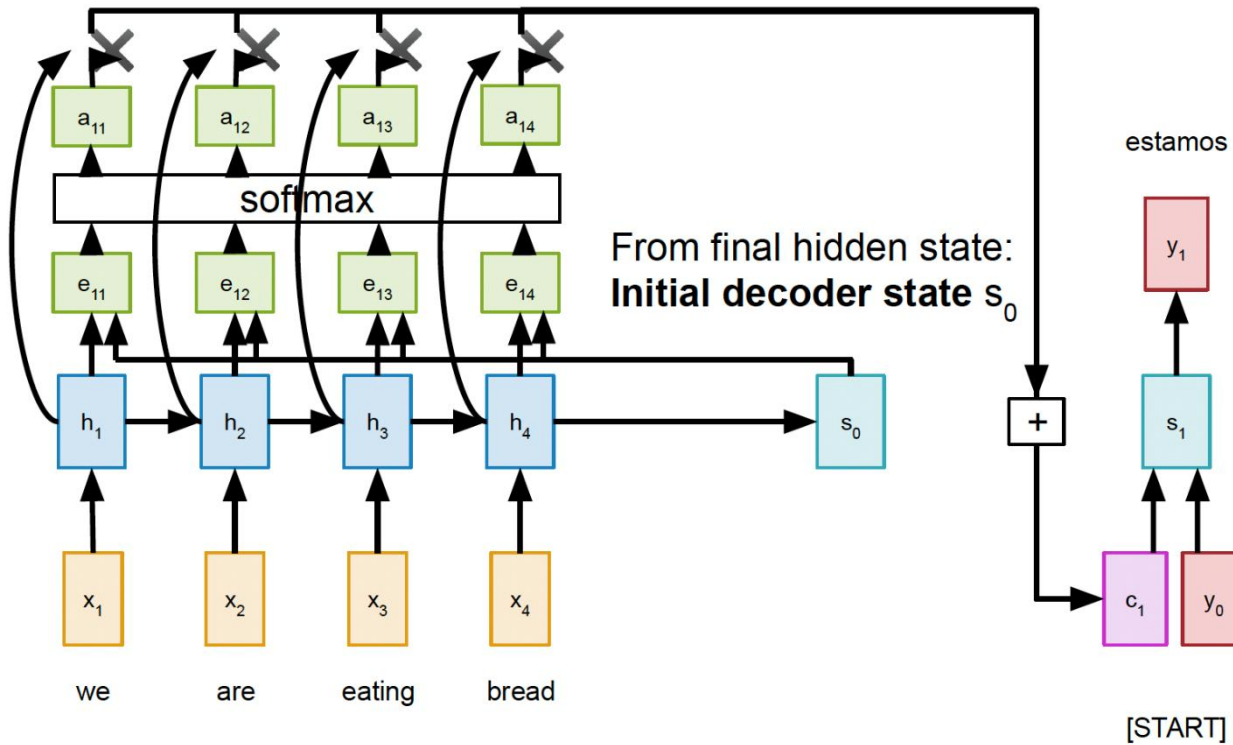

1. 计算对齐分数
(alignment scores)

$$e_{t,i} = f_{\text{attn}}(s_{i-1}, h_i)$$

2. 归一化得到注意力权重
(attention weights)

$$0 < a_{t,i} < 1,$$

$$\sum_i a_{t,i} = 1$$

3. 计算上下文向量

$$c_t = \sum_i a_{t,i} h_i$$

4. 更新 s_t

$$s_t = g_U(y_{t-1}, s_{t-1}, c_t)$$

- Dzmitry Bahdanau, et al. "Neural machine translation by jointly learning to align and translate". In ICLR 2015.

RNN+注意力

□ 引入注意力机制

- 解码器每一步使用不同的上下文向量
- 不同时刻关注输入序列的不同部分

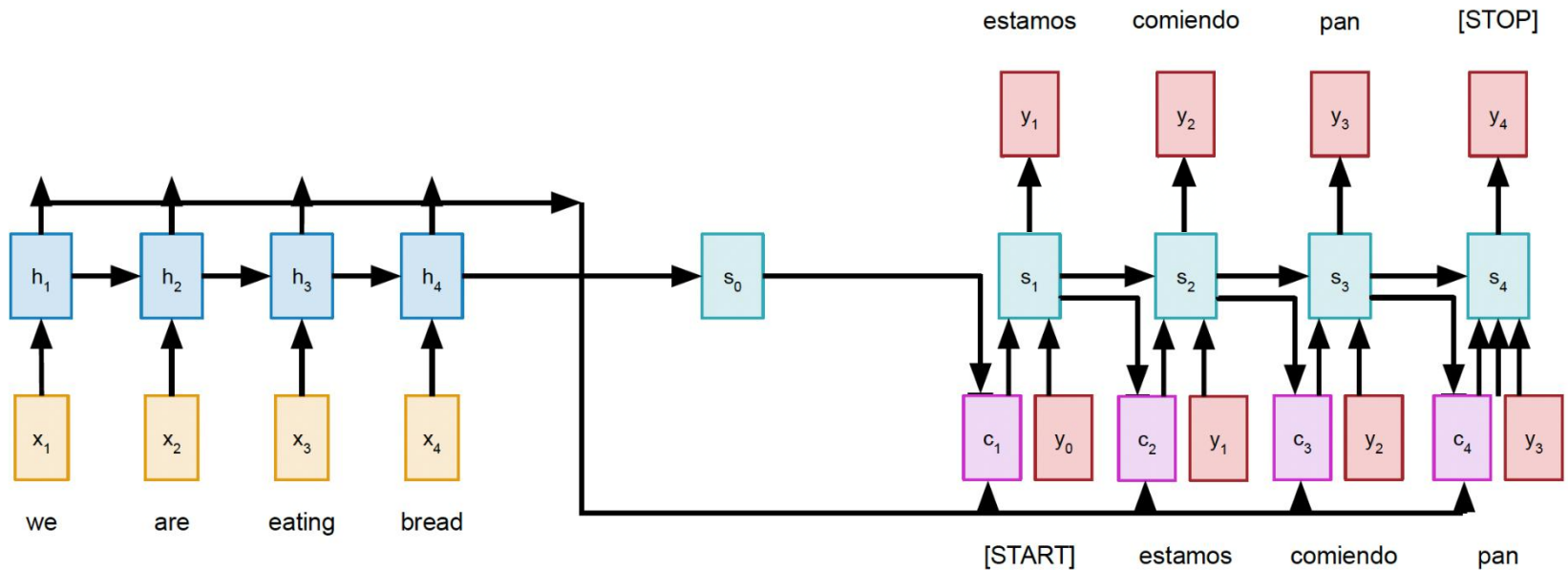

- Dzmitry Bahdanau, et al. "Neural machine translation by jointly learning to align and translate". In ICLR 2015.

RNN+注意力

□ Image Captioning

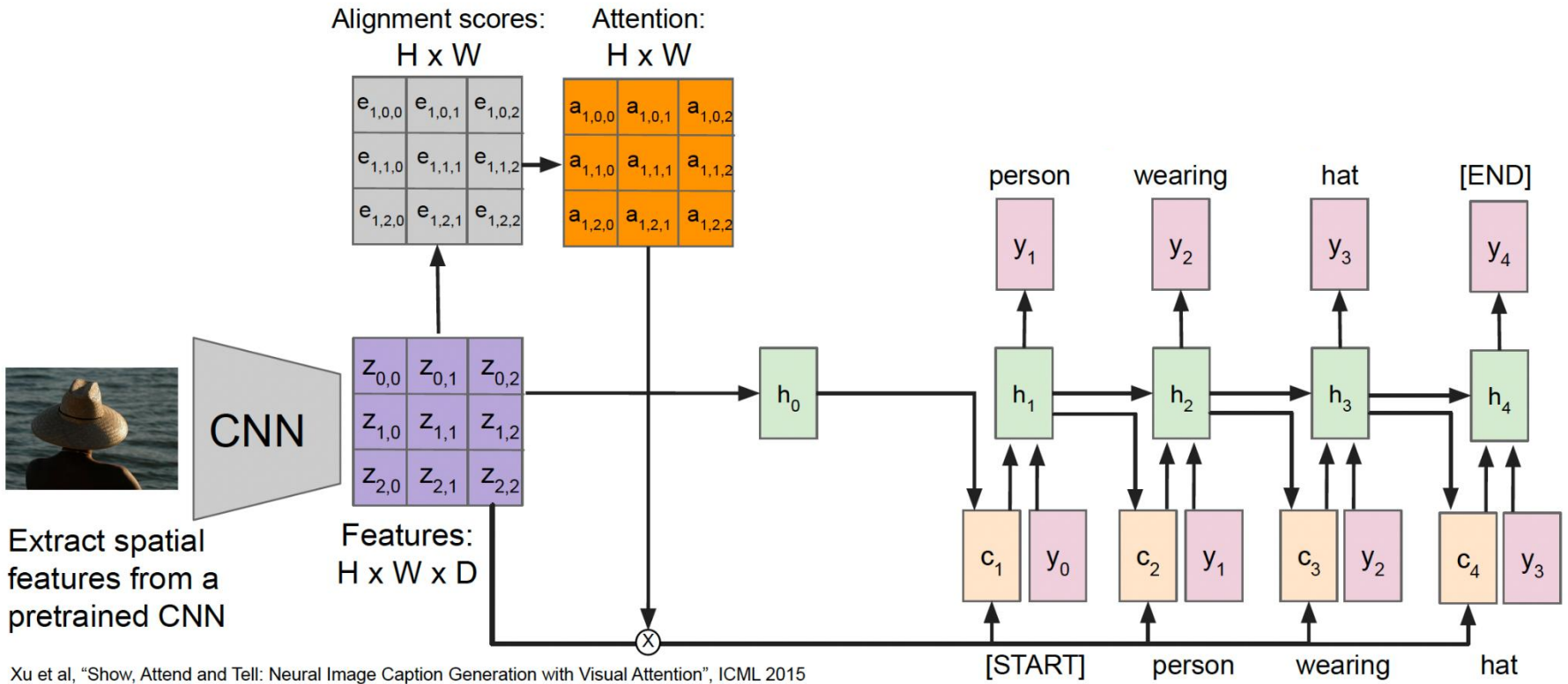

注意力机制

□ 注意力机制

- 注意力模块在计算的时候需要用到矩阵Q(查询), K(键值), V(值)

$$\text{Attention}(Q, K, V) = \text{softmax}\left(\frac{QK^T}{\sqrt{d_k}}\right)V$$

d_k 是Q, K矩阵的列数, 即向量维度

Q、K 相似性矩阵计算

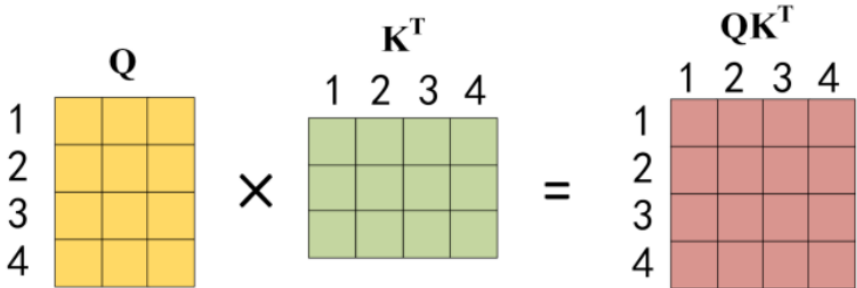

相似性矩阵归一化

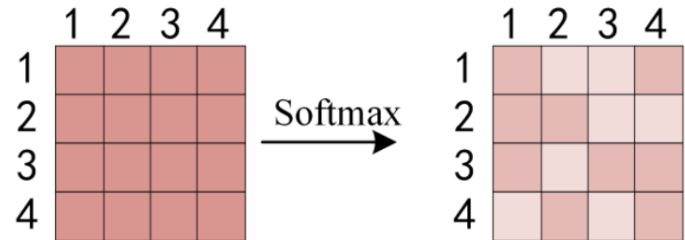

通过相似性矩阵对 V 加权求和

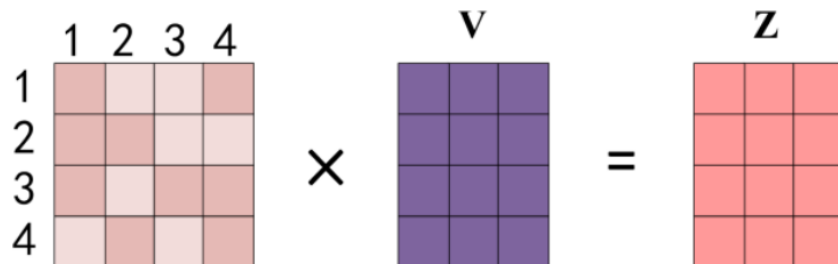

注意力机制

□ 自注意力 (Self Attention)

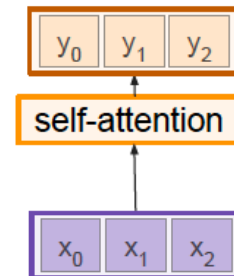
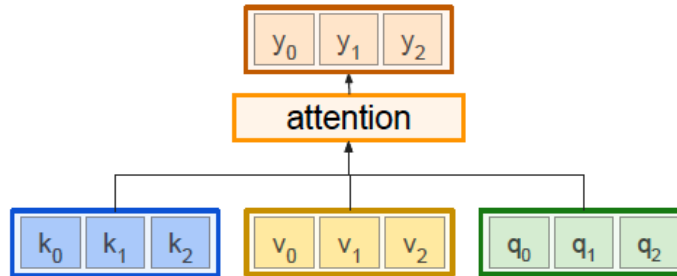

□ 位置编码

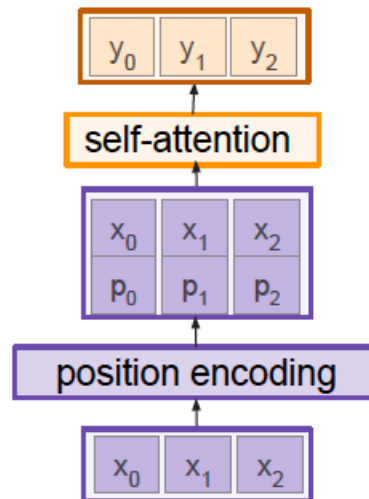

Transformer

□ Transformer概况

- Transformer是Google团队在2017年提出的一种自然语言处理模型
- Transformer模型使用了注意力机制，使得模型可以并行化训练，而且能够拥有全局信息
- 主要由编码器（Encoder）和解码器（Decoder）组成

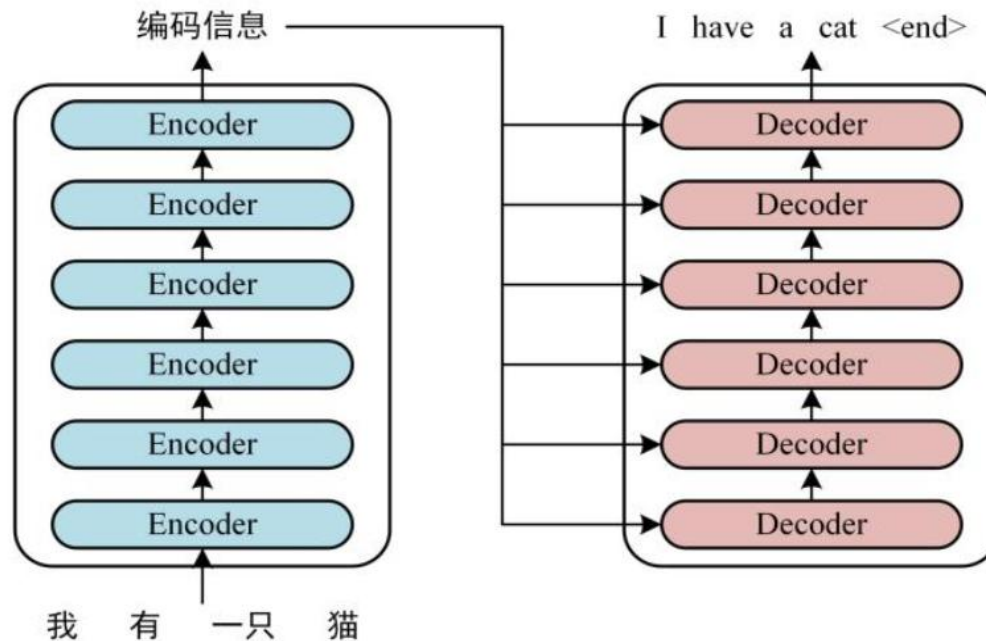

Transformer

□ Transformer概况

- 注意力模块的基本形式
- 多头注意力（Multi-head Attention）：Transformer中，通过构造一系列并列的注意力模块，组成多头注意力机制。通过将输入映射到不同的子空间，有助于学习更加丰富的注意力表达。

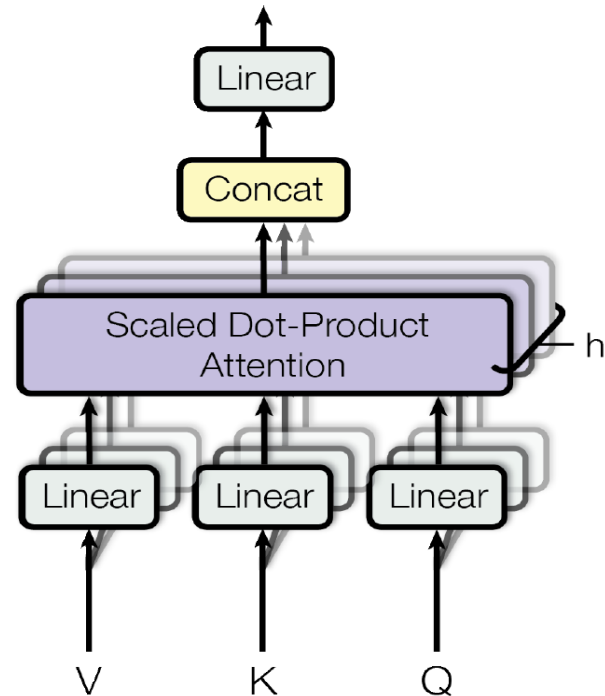
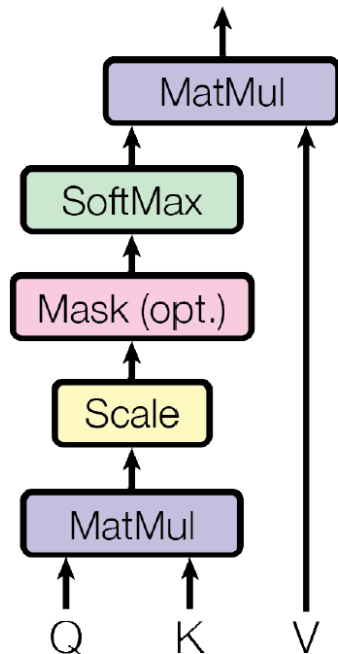

Transformer

□ Transformer概况

- 编码器（encoder）和解码器（decoder）主要由**注意力模块**组成
- 编码器和解码器反复堆叠（ $N=6$ ），以便更好地通过注意力机制获取全局信息

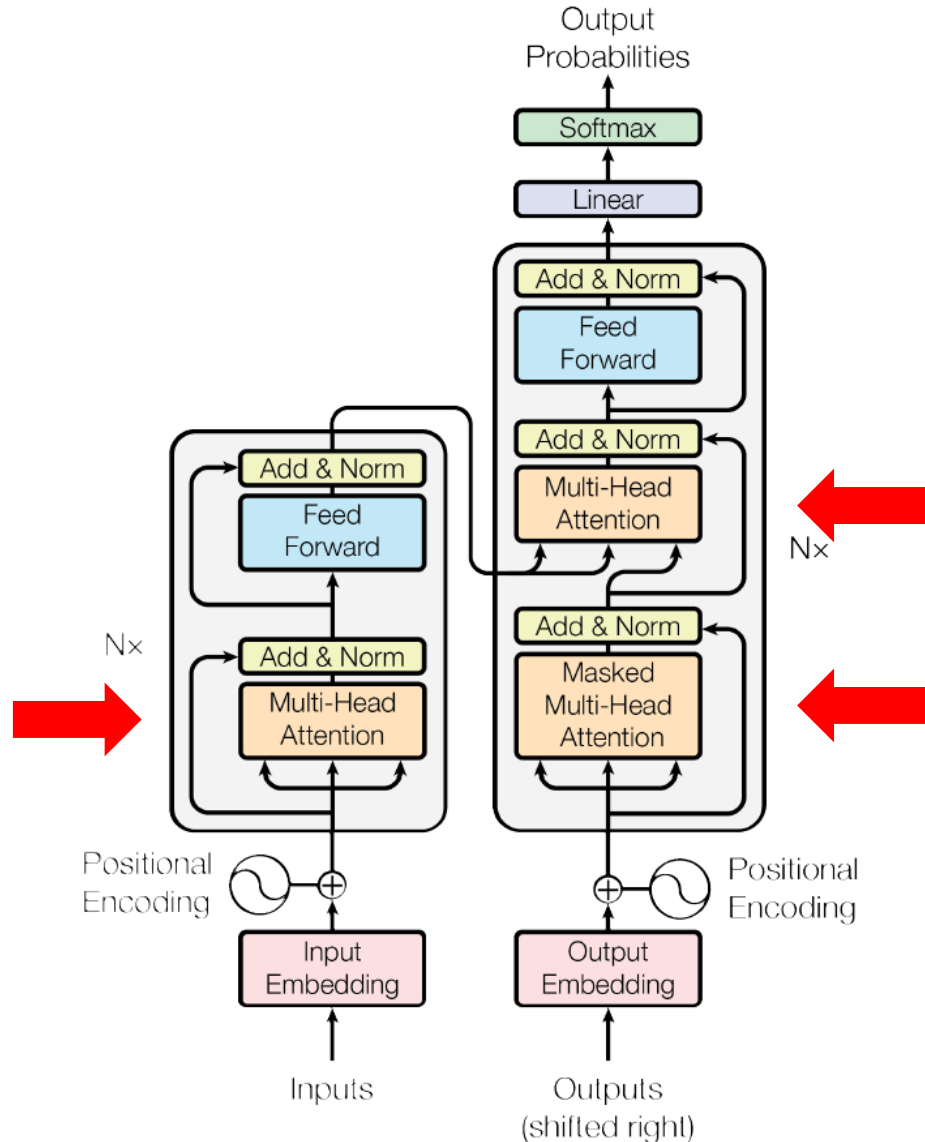

Transformer

□ 视觉Transformer

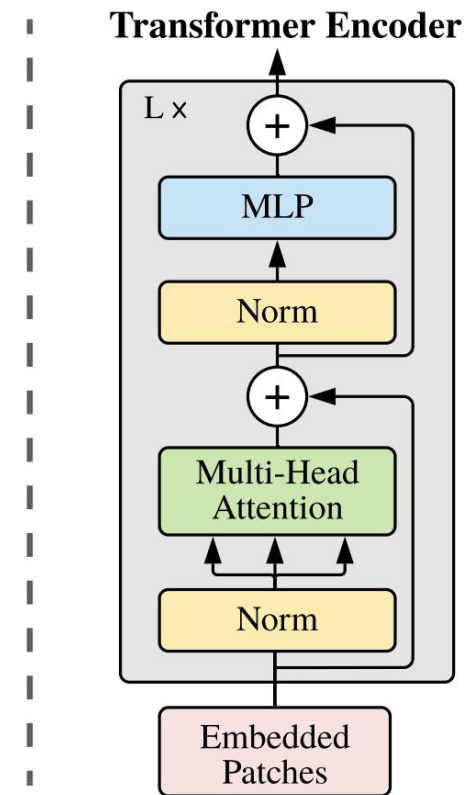
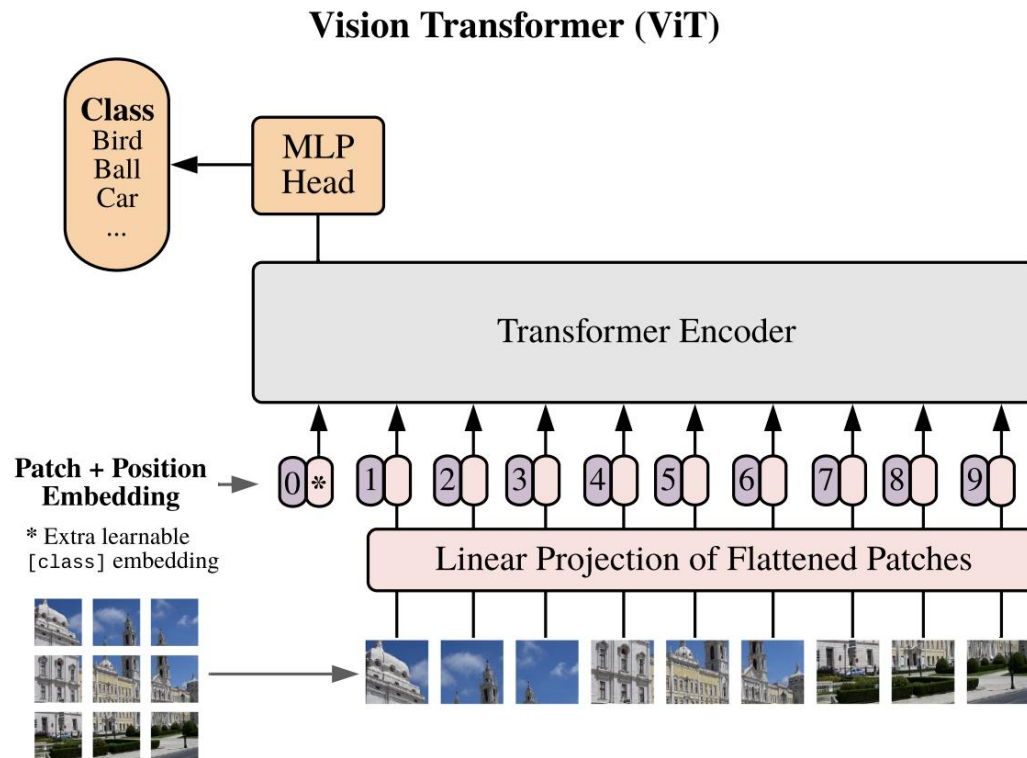

- Alexey Dosovitskiy, et al. “An Image is Worth 16x16 Words: Transformers for Image Recognition at Scale”. In ICLR, 2021.

Transformer VS. CNN

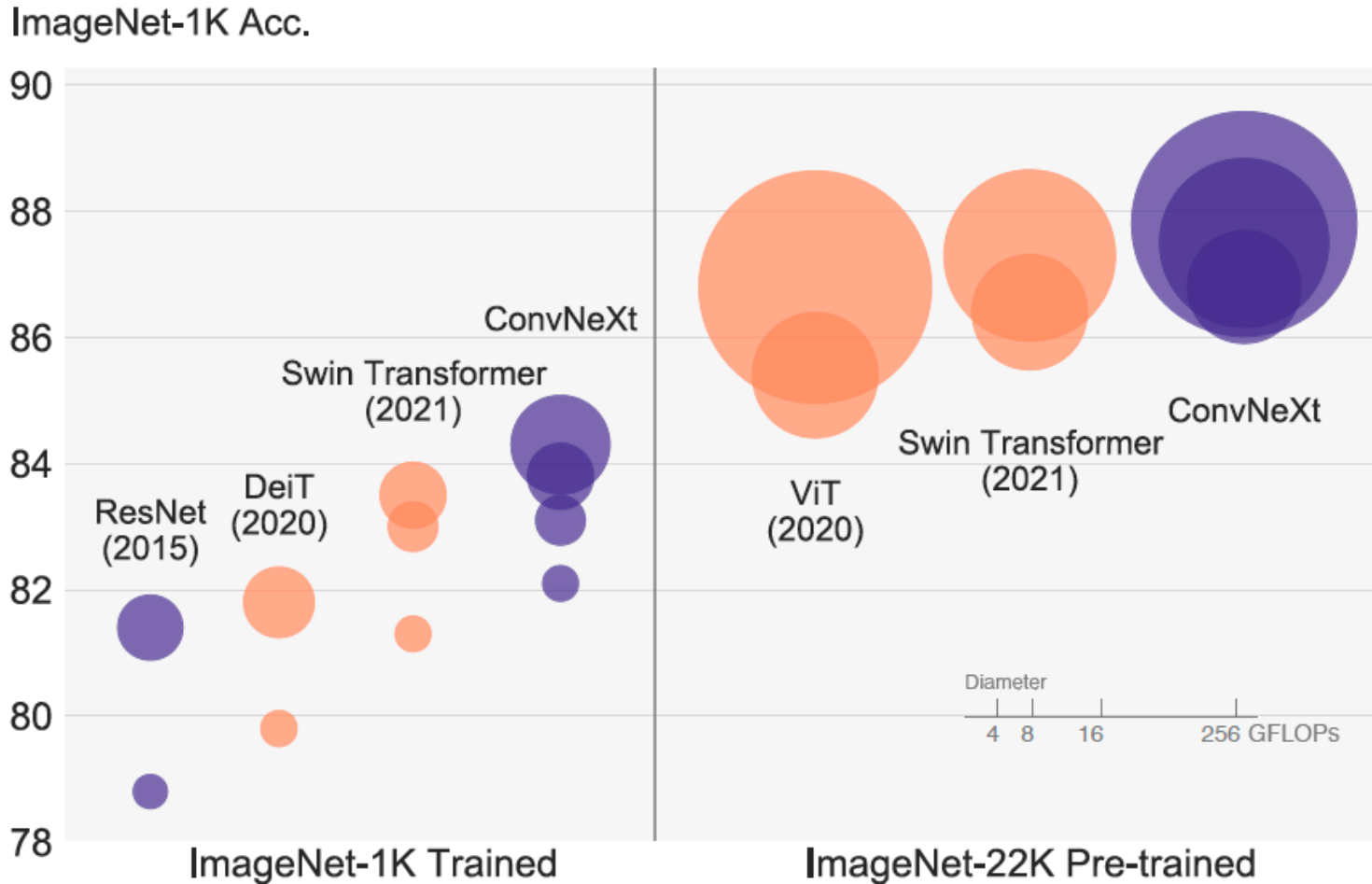

- Z. Liu, et al. “A ConvNet for the 2020s”. In CVPR, 2022.